

UpRight

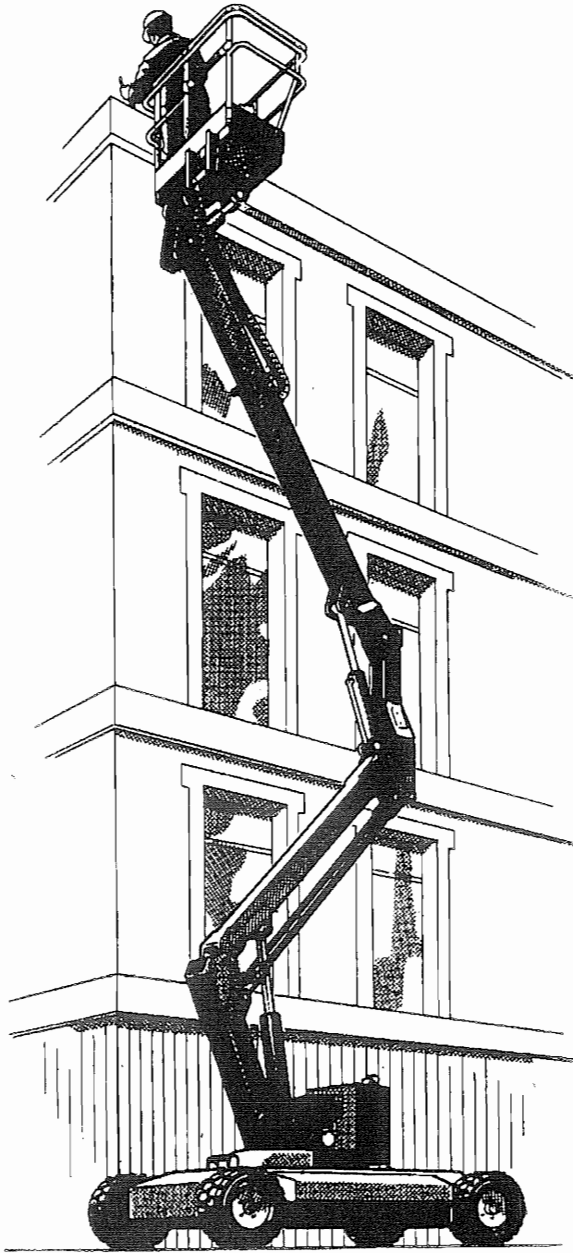

SP37

*SELF PROPELLED
WORK PLATFORM*

**Service &
Parts Manual**

SERVICE & PARTS MANUAL

SP37

Aerial Work Platform

Serial Numbers 1001 to current

When contacting UpRight for service or parts information, be sure to include the MODEL and SERIAL NUMBERS from the equipment nameplate.

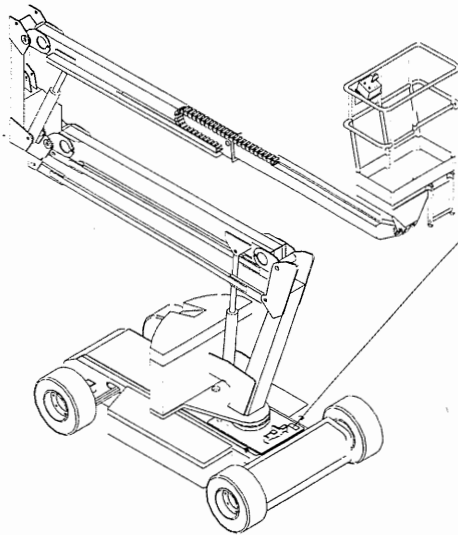



UpRight		POTTERY ROAD, DUN LAOIRE, IRELAND.		CE
MODEL	SP37	SERIAL No.	199	
MAX. PLATFORM HEIGHT	3m	UNLADEN WEIGHT	3200 kg	
MAX. PLATFORM LOAD	200kg	Persons	2	
MAX. LATERAL FORCE	400N	MAX. WIND SPEED	12m/s	
MAX. CHASSIS INCLINATION	8°	BATTERY VOLTAGE	48V	
MAX. GRADEABILITY	36%	CHARGER INPUT VOLTAGE	240V	
MAX. FORWARD SPEED	1.36m/s	NOMINAL POWER	2.2kW	
VEHICLE IDENTIFICATION NUMBER	XJN583700	A001	x	
CAUTION: ONLY TRAINED & AUTHORISED PERSONNEL MAY USE THIS MACHINE—CONSULT OPERATORS MANUAL BEFORE USE. THIS PLATFORM IS NOT ELECTRICALLY INSULATED				



UpRight
UpRight Ireland Ltd.,
Pottery Road,
Dun Laoire,
Ireland.

P/N 58837-000
8/96 Rev. 1

Foreword

SPECIAL INFORMATION

 WARNING 
Indicates the hazard or unsafe practice that could result in severe injury or death.

 CAUTION 
Indicates the hazard or unsafe practice that could result in minor injury or property damage.

Notes: Give helpful information.

WORKSHOP PROCEDURES

CAUTION: Detailed descriptions of standard workshop procedures, safety principles and service operations are not included. Please note that this manual does contain warnings and cautions against some specific service methods which could cause personal injury, or could damage a machine and make it unsafe. Please understand that these warnings cannot cover all conceivable ways in which service, whether or not recommended by UpRight Ireland Ltd., might be done, or of the possible hazardous consequences of each conceivable way, nor could UpRight Ireland Ltd. investigate all such ways. Anyone using service procedures or tools, whether or not recommended by UpRight Ireland Ltd., must satisfy themselves thoroughly that neither personal safety nor machine safety will be jeopardised.

All information contained in this manual is based on the latest product information available at the time of printing. We reserve the right to make changes at any time without notice. No part of this publication may be reproduced, stored in retrieval system, or transmitted, in any form by any means, electronic, mechanical, photocopying, recording, or otherwise, without prior written permission of the publisher. This includes text, figures and tables.

Introduction & Specifications	1.0
General description and machine specifications	

Machine Preparation	2.0
Information on preparation for use & shipment, transporting and storage.	

Operation	3.0
Operating instructions and safety rules.	

Maintenance	4.0
Preventative maintenance and service information	

Troubleshooting	5.0
Causes and solutions to typical problems	

Schematics	6.0
Schematics and valve block diagram with description and location of components	

Illustrated Parts Breakdown	7.0
Schematics and valve block diagram with description and location of components	

Foreword

NOTES

Table of Contents

Section No.	Page No.	Section No.	Page No.
1.0 Introduction & Specifications			
1.0	Introduction.....	1-1	
	Purpose.....	1-1	
	Scope.....	1-1	
1.1	General Information.....	1-1	
	Description.....	1-1	
	Purpose and Limitations.....	1-1	
1.2	Specifications.....	1-2	
2.0 Machine Preparation			
2.1	Preparation for use.....	2-1	
2.2	Preparation for shipment.....	2-1	
2.3	Forklifting of workplatform.....	2-2	
2.4	Lifting Work Platform.....	2-2	
2.5	Transport.....	2-2	
2.6	Storage.....	2-2	
	Preservation.....	2-2	
	Batteries.....	2-2	
3.0 Operation			
3.0	Introduction.....	3-1	
	General Functioning.....	3-1	
	Driving.....	3-1	
	Steering.....	3-1	
	Operating the booms.....	3-1	
	Design Features.....	3-1	
3.1	Safety Rules and Precautions.....	3-2	
3.2	Controls and Indicators.....	3-2	
	Platform Controls.....	3-2	
	Chassis Controls.....	3-4	
3.3	Pre-Operation Inspection.....	3-6	
3.4	Operation.....	3-7	
	Elevating platform.....	3-7	
	Lowering platform.....	3-7	
	Drive.....	3-7	
	Emergency Override.....	3-7	
	Non-Powered Descent.....	3-7	
	Manual Tele Retraction.....	3-7	
	Cage Levelling.....	3-7	
4.0 Maintenance			
4.0	Introduction.....	4-1	
4.1	Preventative Maintenance.....	4-1	
	Preventative Maintenance Table Key..	4-2	
	Preventative Maintenance Report.....	4-2	
4.2	Maintenance on Elevated Platform.....	4-3	
4.3	Battery Maintenance.....	4-3	
	Battery Inspection and Cleaning.....	4-3	
	Battery Charging.....	4-4	
	Battery Cell Forming.....	4-4	
4.4	Lubrication.....	4-5	
	Hydraulic Oil Reservoir and Filter.....	4-6	
	Fluid Level.....	4-6	
	Oil and Filter Replacement.....	4-6	
4.5	Setting Hydraulic pressures.....	4-6	
	Main Relief valve.....	4-6	
	Slew Cross-Line Relief Valves.....	4-7	
4.6	Switch Adjustments.....	4-8	
	Slew Cut-Out Limit Switch.....	4-8	
	Boom Rest Limit Switch.....	4-9	
	8m Cut-Out Limit Switch.....	4-9	
4.7	Hydraulic Manifold.....	4-10	
	Removal.....	4-10	
	Disassembly.....	4-10	
	Cleaning and Inspection.....	4-10	
	Assembly.....	4-10	
	Installation.....	4-10	
4.8	Hydraulic Pump	4-12	
	Removal.....	4-12	
	Installation.....	4-12	
4.9	Hydraulic Cylinders.....	4-12	
	Removal and Installation.....	4-12	
	Slave Levelling Cylinder.....	4-12	
	Master Levelling Cylinder.....	4-13	
	Telescopic Cylinder.....	4-13	
	Lower Lift Cylinder.....	4-14	
	Upper Lift Cylinder.....	4-15	
	Steering Cylinder.....	4-15	
4.10	Disassembly of Hydraulic Cylinders.....	4-16	
	Cleaning and Inspection.....	4-16	
	Assembly.....	4-16	
4.11	Motor/Pump Set Maintenance.....	4-18	
4.12	Drive Motor Maintenance	4-19	
4-13	Drive Reduction Gearbox Maintenance....	4-21	
5.0 Troubleshooting			
5.0	Introduction.....	5-1	
	General Procedure.....	5-1	
6.0 Schematics			
6.0	Introduction.....	6-1	
6.1	Electrical Schematic.....	6-3	
6.2	Hydraulic Schematic.....	6-9	
7.0 Illustrated Parts Breakdown			
7.0	Introduction.....	7-1	
7.1	Index.....	7-1	
7.2	Chassis Assembly.....	7-2	
7.2	Booms and Posts Assembly.....	7-4	
7.2	Cage and Cradle Assembly	7-6	
7.2	Slew Gearbox Assembly	7-8	
7.2	Master/Slave Cylinder Assembly	7-10	
7.2	Lower Lift Cylinder Assembly.....	7-12	
7.2	Upper Lift Cylinder Assembly.....	7-14	
7.2	Tele Cylinder Assembly	7-16	
7.2	Motor Controller Assembly	7-18	
7.2	Lower Control Box Assembly	7-20	
7.2	Upper Control Box Assembly	7-22	
7.2	Label Kit.....	7-24	
7.2	Hose Assembly.....	7-26	
7.2	Motor/Pump Assembly.....	7-28	
7.2	Rear/Front Wheel Assembly	7-30	

Table of Contents (cont'd.)

Section No.		Page No.
7.2	Hydraulic Manifold Block Assembly.....	7-32
	Steering Cylinder Assembly.....	7-34
	Traction Motor Assembly.....	7-36
	Drive Reduction Gearbox Assembly....	7-38
	Cables and Electrical Components	7-40

List of Illustrations

Fig.	Title	Page No.
1-1	SP37 Work Platform.....	1-1
2-2	Lifting the SP37.....	2-2
3-1	Platform Controls.....	3-3
3-2	Lower Controls.....	3-4
3-3	Emergency Lowering Valve.....	3-8
3-4	Manual Tele Retraction Hand Pump.....	3-8
4-2	Battery Charger.....	4-4
4-3	Lubrication Points.....	4-5
4-4	Oil and Filter Replacement.....	4-6
4-5	Main Manifold Block.....	4-7
4-6	Slew Cut-out Limit Switch.....	4-8
4-7	Boom Rest Limit Switch.....	4-9
4-8	8m Cut-out Limit Switch.....	4-9
4-9	Main Manifold Block.....	4-11
4-10	Hydraulic Pump.....	4-12
4-11	Slave Levelling Cylinder.....	4-12
4-12	Master Levelling Cylinder.....	4-13
4-13	Tele Cylinder.....	4-13
4-14	Lower Lift Cylinder.....	4-14
4-15	Upper Lift Cylinder.....	4-15
4-16	Steering Cylinder.....	4-15
4-17	Hydraulic Cylinder Components.....	4-16
4-18	Replacement of Motor Brushes.....	4-18
4-19	Traction Motor Maintenance.....	4-20
4-20	Drive Reduction Gearbox.....	4-22
6-1	Electrical Schematic.....	6-5
6-2	Hydraulic Schematic.....	6-9
6-3	Hydraulic Manifold.....	6-9

List of Tables

Table	Title	Page No.
1-1	Specifications.....	1-2
3-1	Platform Controls and Indicators.....	3-2
3-2	Lower Controls.....	3-5
4-1	Preventative Maintenance.....	4-2
5-1	Trouble Shooting.....	5-2
6-1	Electrical Schematic Legend.....	6-3, 6-4
6-2	Hydraulic Schematic Legend.....	6-8

1.0 Introduction

PURPOSE

This manual provides illustrations and instructions for the operation and maintenance of the SP37 Work Platform manufactured by Upright Ireland Ltd, Dun Laoire, Ireland. (See Figure 1-1).

SCOPE

This manual includes both operation and maintenance responsibilities concerning the SP37 Work Platform's readiness. The Maintenance Section covers scheduled maintenance, trouble shooting, repair, adjustment and replacement.

1.1 General Information

DESCRIPTION

The SP37 Work Platform is a self-propelled aerial work platform designed to be used as a means of elevating personnel and equipment and to provide a mobile work platform. It is designed to provide mobility with the platform in a raised or lowered position. Travel with the platform elevated is automatically limited to the low speed range.

PURPOSE AND LIMITATIONS

The objective of the SP37 Work Platform is to provide a quickly deployable, self-propelled, variable height work platform. The elevating function shall only be used when the work platform is on a firm level work area. The platform is intended to be self-propelled when in relatively close proximity to the work area.

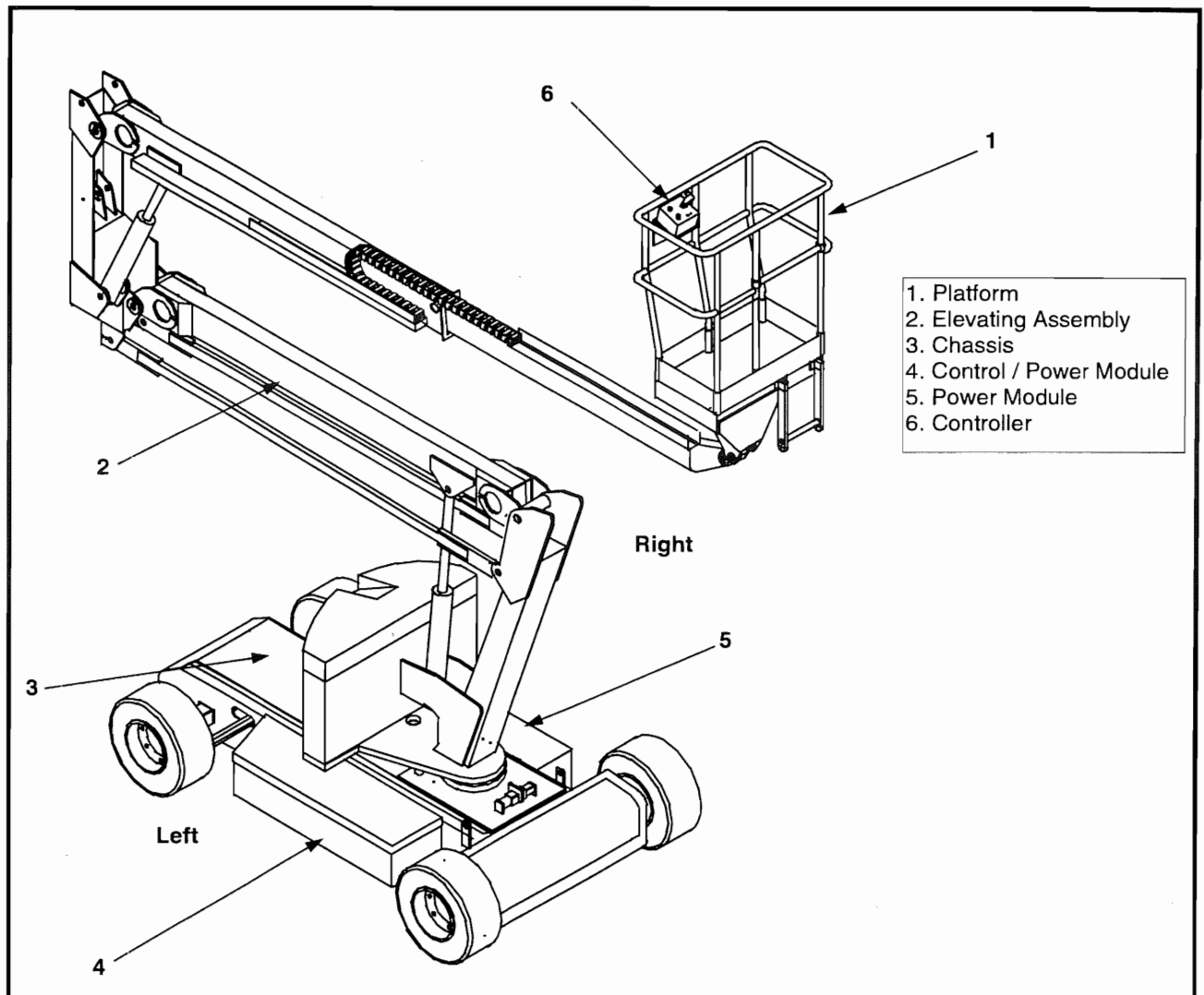

Figure 1-1: SP37 Work Platform

1.2 Specifications*

Table 1-1: Specifications

ITEM	METRIC	IMPERIAL
Platform Size	0.6m x 1.2m (inside guardrails)	2.0 ft x 3.9 ft
Max. Platform Capacity	215kg	473 lbs
Max. No. of occupants	2 People	2 People
Max. Working Height	13.3m	43.6 ft
Max. Platform Floor Height	11.3m	37.1 ft
Max. Working Outreach	6.1m	20.0 ft
Stowed Dimensions:		
Length	3.86m	12.7 ft
Width	1.5m	4.9 ft
Height	1.98m	6.5 ft
Wheelbase	2.0m	6.6 ft
Ground clearance	0.14m	5.5 inches
Gross weight	3207kg	7070 lbs
Travel Speed stowed	4.3 km/hr.	2.7 mph
Travel Speed elevated	0.5 km/hr	0.3 mph
Maximum gradeability	36% (20°)	36% (20°)
Inside turning radius	2.20m	7.2 ft
Outside turning radius	4.10m	13.5 ft
Energy source	48v DC 8 x 6V 220 Ah batteries	
System Voltage	48v	
Battery Charger	48v	
Hydraulic Tank Capacity	25 litres	6.5 gallons
Max. Hydraulic System Pressure	145 bar	2100 p.s.i
Hydraulic Fluid	ISO # 46	ISO # 46
Lift System	2 x Lift cylinders and 1 x Telescopic cylinder	
Control System	One-hand proportional joystick operating energy-efficient motor control system	
Wheels/Tyres	400mm diameter steel disc wheel with solid all-surface tyres	
Braking	Automatic spring applied - hydraulic release.	

***Specifications subject to change without notice.**

2.1 Preparation for use

Read and familiarise yourself with all operating instructions before attempting to operate machine.



1. Check Hydraulic oil level.
2. Check that batteries are charged.

2.2 Preparation for Shipment

1. Lubricate machine per lubrication instructions in Section 4.4, Maintenance.
2. Fully Lower the platform.
3. Ensure transport stop is in place.
4. Disconnect the negative (-) battery cable from the battery terminal.

2.3 Forkifting of Work Platform

NOTE: Forklifting is for transport only.

 CAUTION 
<p>See specifications for weight of work platform and be certain that lifting apparatus is of adequate capacity to lift platform.</p>

Forklift from the side by lifting under the chassis modules (Figure 2-2).

2.4 Lifting Work Platform

Secure straps to chassis lift points **only** (Figure 2-2).

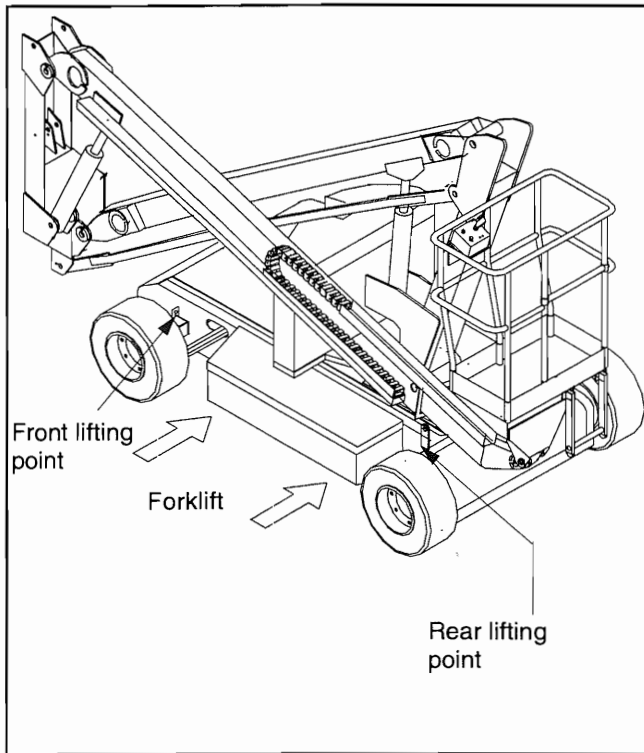

Figure 2-2: Lifting the SP37

2.5 Transport

1. Manouver the work platform into transport position and chock wheels.
2. Secure the work platform to the transport vehicle with chains or straps of adequate load capacity attached to the lifting lugs on the chassis.
3. Ensure transport stop is in place.

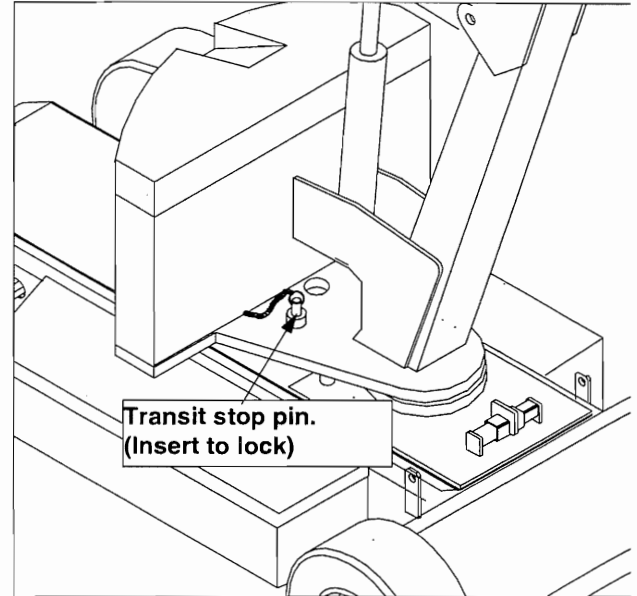

Figure 2-3: Transit stop

2.6 Storage

No preparation is required for normal storage. Regular maintenance per *Table 4-1* should be performed. If The work platform is to be placed in long term storage (dead storage) use the following preservation procedure.

PRESERVATION

1. Clean painted surfaces. If the painted surface is damaged, repaint.
2. Fill the hydraulic tank to operating level **with the platform fully lowered**. Fluid should be visible on the dip stick.
3. Coat exposed portions of cylinder rods with a preservative such as multipurpose grease and wrap with barrier material.
4. Coat all exposed unpainted metal surfaces with preservative.

BATTERIES

1. Disconnect the battery ground cable and secure to the chassis.
2. Disconnect the remaining battery leads and secure to the chassis.
3. Remove the batteries and place in alternate service.

3.0 Introduction

General functioning

Refer to the Hydraulic and Electrical Schematics, Section 6

The battery powered electric motor directly drives a hydraulic pump. The pump supplies oil under pressure to the various platform functions. The oil flow is directed to the different functions by electrically activated solenoid valves.

Driving

With both emergency stop switches **ON** (pull out), the keyswitch set to platform controls, the deadman trigger depressed and the drive/lift switch in **DRIVE** the machine will drive at a speed proportional to the angle of the control lever from centre and steer in the direction you want to travel.

The drive wheels are driven by two D.C electric traction motors coupled to two braked gearboxes. Upon moving the control lever the brake chambers receive a flow of pressurised oil which releases the brakes. When the control lever is in the neutral position the brake chamber is vented and an internal spring in the gearbox reapplies the brakes. When the booms are off the boom rest (i.e. elevated) the current that is fed to the drive motors is reduced and the elevated drive speed is significantly slower than the booms stowed drive speed for safety reasons.

Steering

Steering left or right will energise the steering coils and allow oil to enter the full-bore or annular side of the steering cylinder thereby turning the wheels in the chosen direction.

Operating the booms

The keyswitch can be switched to platform or chassis controls.

Platform controls provide variable speeds for the boom functions through the use of a joystick. This is achieved using a motor control unit which varies the speed of the motor/pump unit and increases or decreases the flow of oil to the different functions. This control unit (located in the power/control module) receives a control signal from the joystick on the upper controls.

The speed of the motor increases as the control lever is pushed further away from the neutral (stopped) position.

Note: A deadman trigger is an integral part of the joystick. This must be depressed for the functions to operate. (This safety feature prevents unwanted movement of the booms in the case of inadvertent movement of the joystick.

Chassis controls provide a fixed speed for each of the boom functions.

Design Features

The SP37 Series Work Platform has the following features:

- The drive speed is limited to creep speed when operating the work platform while the platform is elevated.
- The slew cut-out interlock ensures that the boom support structure is clear of the wheels before slewing can commence.
- The energy-efficient motor control units provides long battery life and smooth proportional control of the boom and drive functions.
- The Master/Slave levelling system ensures that the platform remains level throughout the entire working cycle of the machine.
- All cylinders are fitted with hydraulic hose-burst protection interlocks.
- The on-board charger is fully automatic and charges the batteries efficiently and economically.
- If the work platform starts to become unstable and the tilt unit is activated an alarm will sound in the upper control box. In this situation power is cut to the upper controls to prevent boom movement that might increase instability. An emergency override switch is fitted to allow the booms to be descend at a controlled speed to bring the machine back to a stable position.
- In the event of a power loss the two lift cylinders are fitted with emergency lowering valves which allow the booms to be lowered at a controlled speed by an operator on the ground.

3.1 Safety Rules and Precautions

Before using the SP37 Work Platform:

NEVER operate the machine near power lines. **THIS MACHINE IS NOT INSULATED.**

NEVER elevate the platform unless the machine is on firm level ground.

NEVER sit, stand or climb on guard rail or midrail.

NEVER use ladders or scaffolding on the platform.

NEVER attach overhanging loads or increase platform size.

LOOK up, down and around for overhead obstructions and electrical conductors

DISTRIBUTE all loads evenly on the platform. See Table 1-1 for maximum platform load.

NEVER use damaged equipment. (Contact UpRight Ireland Ltd. for instructions).

NEVER change or modify operating or safety systems.

INSPECT the machine thoroughly for cracked welds, loose hardware, hydraulic leaks, damaged control cable, loose wire connections and wheel bolts.

NEVER climb down an elevating assembly with platform elevated.

NEVER perform service on or in the elevating assembly while the platform is elevated without first blocking or securely slinging the elevating assembly.

NEVER recharge batteries near sparks or open flame; batteries that are being charged emit highly explosive hydrogen gas.

SECURE the work platform against unauthorised use by turning keyswitch off and removing key from switch.

NEVER replace any component or part with anything other than original replacement parts without manufacturer's consent.

3.2 Controls and Indicators

The controls and indicators for operation of the SP37 Work Platform are shown in Figures 3-1 & 3-2. The name and function of each control and indicator are listed in Tables 3-1 & 3-2. The index numbers in the figure correspond to the index numbers in the table. **The operator should know the location of each control and indicator and have a thorough knowledge of the function and operation of each before attempting to operate the unit.**

Table 3-1: Platform Controls and indicators

INDEX NO.	NAME	FUNCTION
1	CONTROL LEVER	Move joystick forward or backwards to proportionally control lift / slew speeds. NOTE: The interlock trigger on the control lever must be pressed to provide power to the controller. This prevents accidental activation of the controller.
*	STEERING SWITCH	Integral with the control lever, moving this rocker switch left or right steers the platform in that direction. Although the steering switch is self-centering the steering system is not. The wheels must be steered back to straight.
2	FUNCTION SELECTOR	This four position switch selects which function is to be controlled by the control lever. Only one function can be selected at a time.
3	ON / EMERGENCY OVERRIDE SWITCH	This three position switch has 2 functions. (a) On: When turned to this position power is allowed to pass to the control circuitry. (b) Emergency Lowering: This position is momentary i.e. the switch must be held in this position, otherwise it will spring return to the neutral position. This allows power to re-enter the controls when it has been cut due to the tilt alarm being activated. Speeds are restricted when this option is used.
4	EMERGENCY STOP SWITCH	Push red button to cut off power to all functions (OFF). Turn clockwise to provide power (ON).

Table 3-1: Platform Controls and indicators (cont'd)

INDEX NO.	NAME	FUNCTION
5	BATTERY CONDITION INDICATOR	This red L.E.D. indicates the condition of the batteries. It is constantly illuminated when the batteries are fully discharged. It flashes repeatedly when the batteries have begun to discharge. It remains off when the batteries are fully charged.
6	POWER INDICATOR	This green L.E.D. indicates that power is now available to the upper controls.

INDEX NO.	NAME	FUNCTION
7	LEVEL SWITCH (Machine Stowed)	This toggle switch allows the cage to have its level adjusted forwards or backwards. The emergency override switch must be operated also for this switch to function.
8	DRIVE/LIFT SELECTOR SWITCH	This 2-position switch selects drive or lift functions.

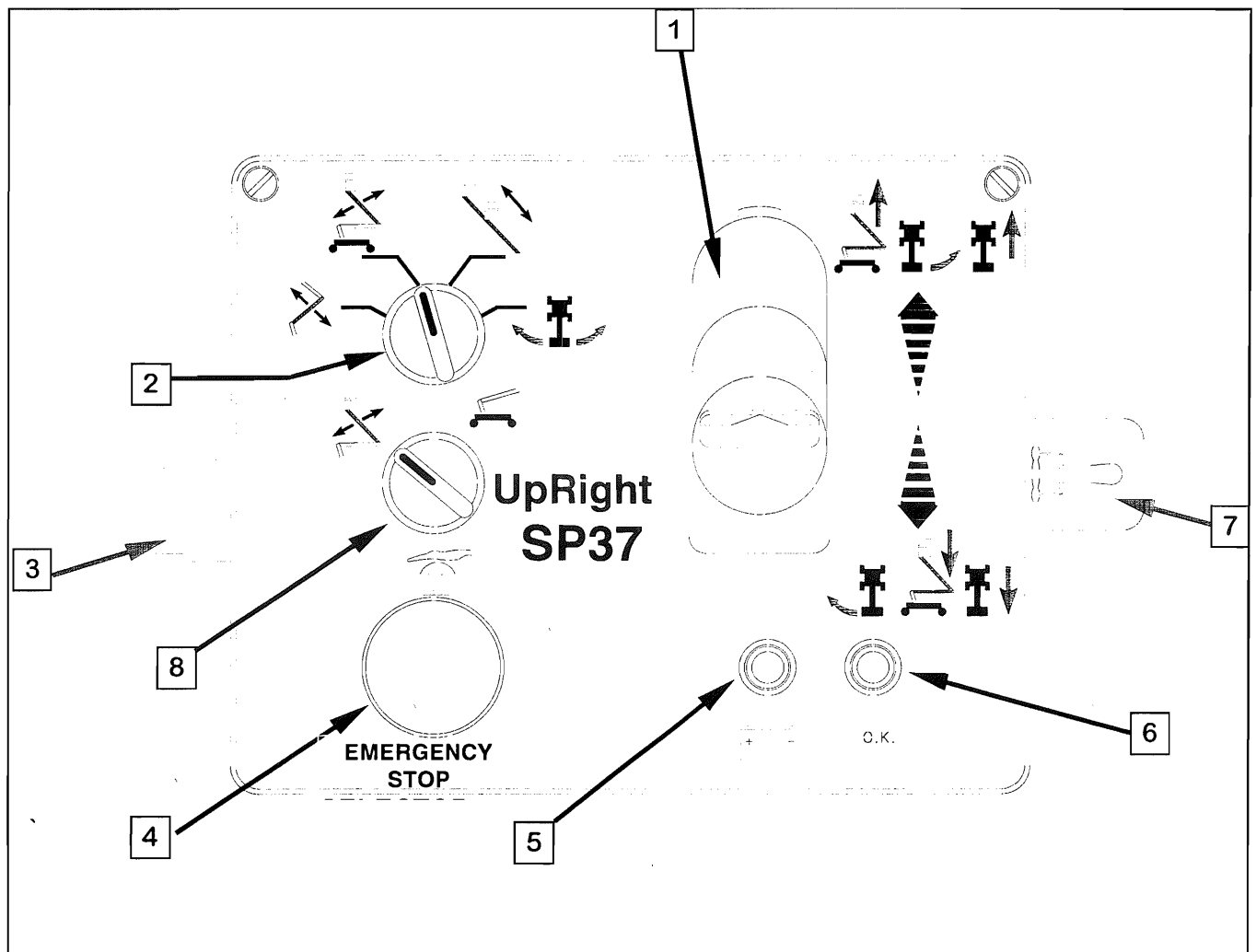

Figure 3-1: Platform Controls

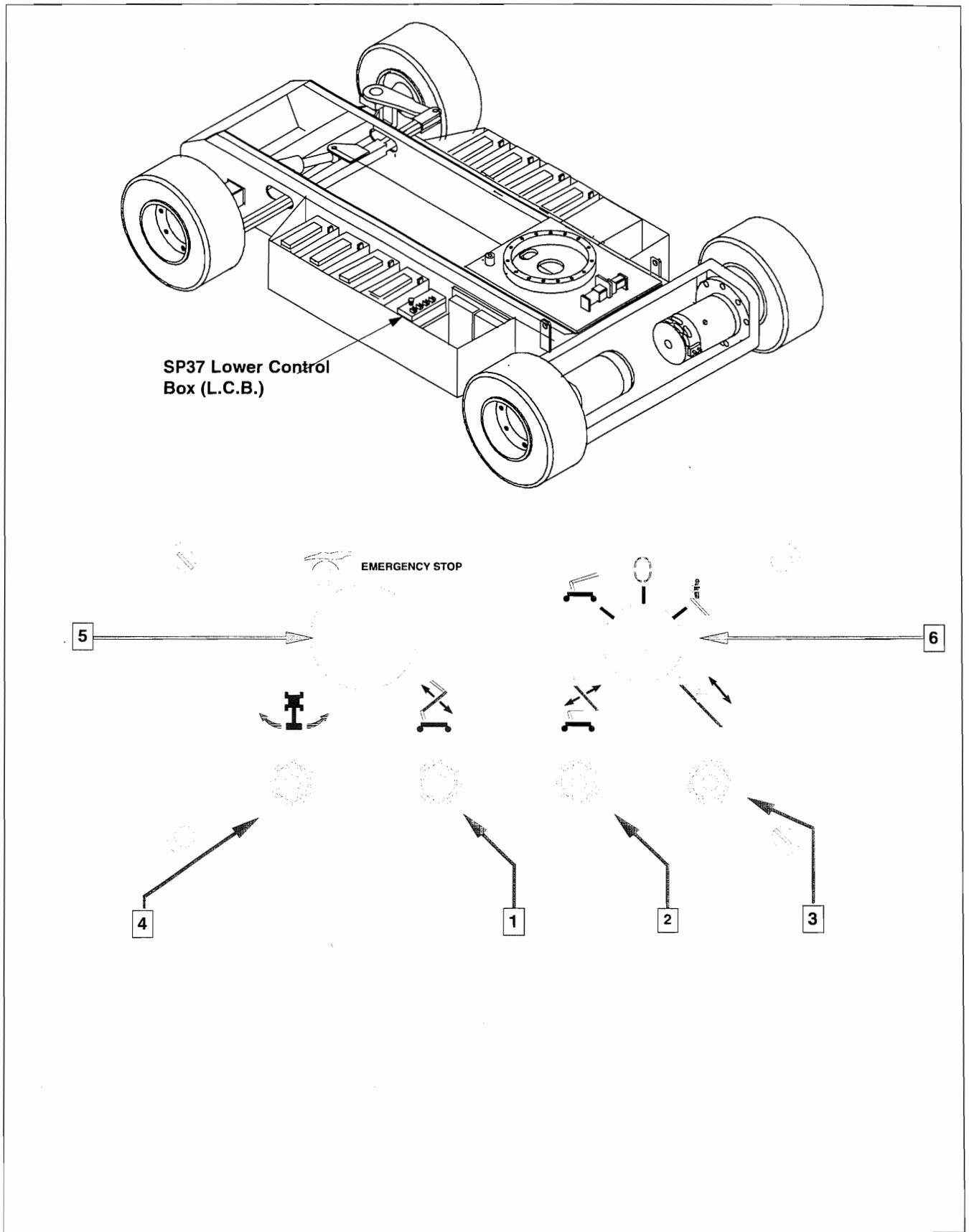

Figure 3-2: Lower Controls

Table 3-2: Lower Controls

INDEX NO.	NAME	FUNCTION
1	LOWER BOOM SWITCH	This two position toggle switch operates the solenoid that feeds oil to the lower lift cylinder. A fixed speed of ascent and descent is only available using this switch.
2	UPPER BOOM SWITCH	This two position toggle switch operates the solenoid that feeds oil to the upper lift cylinder. A fixed speed of ascent and descent is only available using this switch.
3	TELE BOOM SWITCH	This two position toggle switch operates the solenoid that feeds oil to the telescopic cylinder. A fixed speed of extension and retraction is only available using this switch.
4	SLEW SWITCH	This two position toggle switch operates the solenoid that feeds oil to the slew motor. A fixed speed of rotation only available using this switch.
5	EMERGENCY STOP (LOWER CONTROLS)	Push red button to cut off power to all functions (OFF). Turn clockwise to provide power (ON).
6	KEYSWITCH	This three position keyswitch selects either the lower controls or the upper controls. The key is removable in all three positions to avoid tampering by unauthorised personnel during operation.

3.3 Pre-Operation Inspection

Read, understand and follow all safety rules and operating instructions and then perform the following steps each day before use.

1. Check the level of the hydraulic oil with the platform fully lowered and the booms retracted. Remove filler/breather cap from top of hydraulic reservoir. Level should be between min./max. marks on dipstick
Top up with oil (GRADE: ISO# 46) if necessary.
2. Check that fluid level in the batteries is correct (10mm above the plates).
3. Verify that the batteries are charged.
4. Check that the A.C. extension chord has been disconnected from the charger.
5. Carefully inspect the entire work platform for damage such as cracked welds or structural members, loose or missing parts, oil leaks, damaged cables or hoses, loose connections and tyre damage.
6. Move machine, if necessary, to unobstructed area to allow room for full elevation.
7. Pull out both chassis and platform emergency stop buttons to turn ON (Figure 3-1 & 3-2).
8. Turn the chassis keyswitch to CHASSIS (figure 3-2).
9. Visually inspect the cylinders, hoses and cables for damage or erratic operation.
Check for missing or loose parts.
10. Remove control module cover to operate lower controls.
- 10a. Disengage transport stop.
11. Fully elevate platform and slew machine through 180 degrees in both directions.
12. Visually inspect the elevating assembly, lift cylinders, level cylinders and cables and hoses for damage, erratic operation. Check that platform is levelling throughout its cycle. Check for missing or loose parts.
13. Check that the emergency lowering on both lift cylinders is operating correctly as detailed in section 3.4.
14. Push emergency stop button. The controls should not function.
15. Release emergency stop button.
16. Turn keyswitch to platform and climb into platform.
17. Operate lower boom up and press emergency stop button while doing so. Machine should stop and no other functions should be available.
18. Operate manual tele retraction as detailed in section 3.4.
19. Release emergency stop button. Raise lower boom such that 2nd post is not above the drive wheels. Select slew function. Slew the machine left or right.
Slew function should not operate. (This is to provide protection for the drive wheels).
20. Raise lower boom such that the 2nd post is above the drive wheels. Slew machine left or right. Slew function should now operate.
21. Push the emergency stop button. The controls should not function.
22. Release emergency stop button.
23. Position the drive/lift switch to DRIVE.
24. While depressing the interlock lever, slowly position the control lever to FORWARD then REVERSE to check for speed and directional control. The farther you push or pull the control lever from center the faster the machine will travel. NOTE: Slow speed when elevated.
25. Push steering switch RIGHT then LEFT to check for steering control.
26. Stow booms and drive. Maximum drive speed should now be available.
27. Drive machine onto a slope greater than 3°. Speed should be reduced and alarm should sound.
28. Emergency override will only work when tilt sensor is activated.

3.4 Operation

Before operating work platform ensure that pre-operation and safety inspection has been completed, any deficiencies have been corrected and the operator has been corrected and the operator has been thoroughly trained on this machine. The operator must read, fully understand and follow the Operator Manual.

Raising and lowering the platform

Lower Controls:

With the keyswitch in the ground control position the booms can be operated using the lower controls which are located under the glass fibre cover of the control module.

Note: The slew function is disabled until the second post is raised above the drive wheels (to prevent damage to the wheels).

Each function is operated by actuating the relevant control switch according to the legend plate on the lower control box. The speed of each function is fixed when operating from the lower controls. Variable speed is available only from the upper controls.

Upper controls:

To operate the booms from the upper controls, turn the key in the keyswitch on the lower control box to upper controls. Climb into the basket and operate the controls according to the upper control legend.

Note: The interlock lever (coloured red) on the control joystick must be depressed for the functions to operate. (This safety feature prevents unwanted movement of the booms in the case of inadvertant movement of the control joystick.)

Proportion control is available from the upper controls. This is achieved using a motor control unit which varies the speed of the motor/pump unit and increases or decreases the flow of oil to the different functions. This control unit (located beside the lower controls) receives a control signal from the joystick on the upper controls. The speed of the motor increases as the control lever is pushed further away from the neutral (stopped) position.

Drive

To drive the SP37 the drive/lift selector switch should be turned to DRIVE. The further away the joystick control lever is pushed away from the central position the faster the drive motors will turn. This is achieved through the second motor control unit (traction control unit). It varies the current that is fed to the drive motors.

Emergency override

In the event of the tilt unit being deactivated, power to the upper controls is cut.

The emergency override switch (fig. 3-1) can be used to bring the machine into a non-tilted position and restore power. The switch is momentary which means that it must be held in position while operating the necessary function.

Non-Powered descent (Figure 3-3)

In the event of a loss in electrical power the two lift cylinders can be lowered manually. The lower lift cylinder must be lowered first.

At the base of the cylinder there is a red knob that can be turned to allow oil to leave the cylinder at a controlled rate. When the cylinder is retracted it is then possible to lower the upper lift cylinder by the same means.

Be sure to retighten both valves when this procedure is complete.

NOTE: On CE machines and machines of serial number > 1060, the round knob must be pushed to release the oil from the cylinder. This knob resets itself automatically by spring return.

If operating the platform from the upper controls, this operation must be carried out by a second person standing at the chassis.

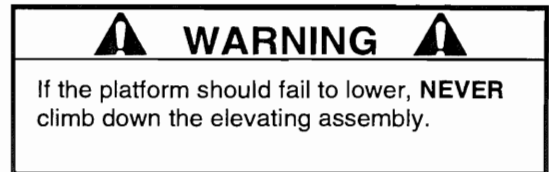

* Manual Tele Retraction (Figure 3-4)

In the event of loss of electrical power the tele cylinder can be retracted as follows:

1. Remove the glass fibre cover from the chassis body.
2. Turn the shut-off ball valve lever through 90° (This lever is located close to the handpump near the tank)
3. Operate handpump to retract the tele cylinder.
4. When the cylinder is retracted turn shut-off ball valve lever back through 90° to its original position.
5. Reposition cover on chassis.

Levelling

The platform can be levelled from the Upper controls using the levelling switch (see Figure 3-1)

This switch is for fine adjustment of the slave levelling cylinder. Care should be taken when performing this operation. The switch should be operated in short bursts to level the cage **slowly**.

NOTE: CE machines will only allow the cage to be levelled when the boom rest limit switch is activated i.e. when all the booms are fully stowed.

* OPTIONAL FEATURE

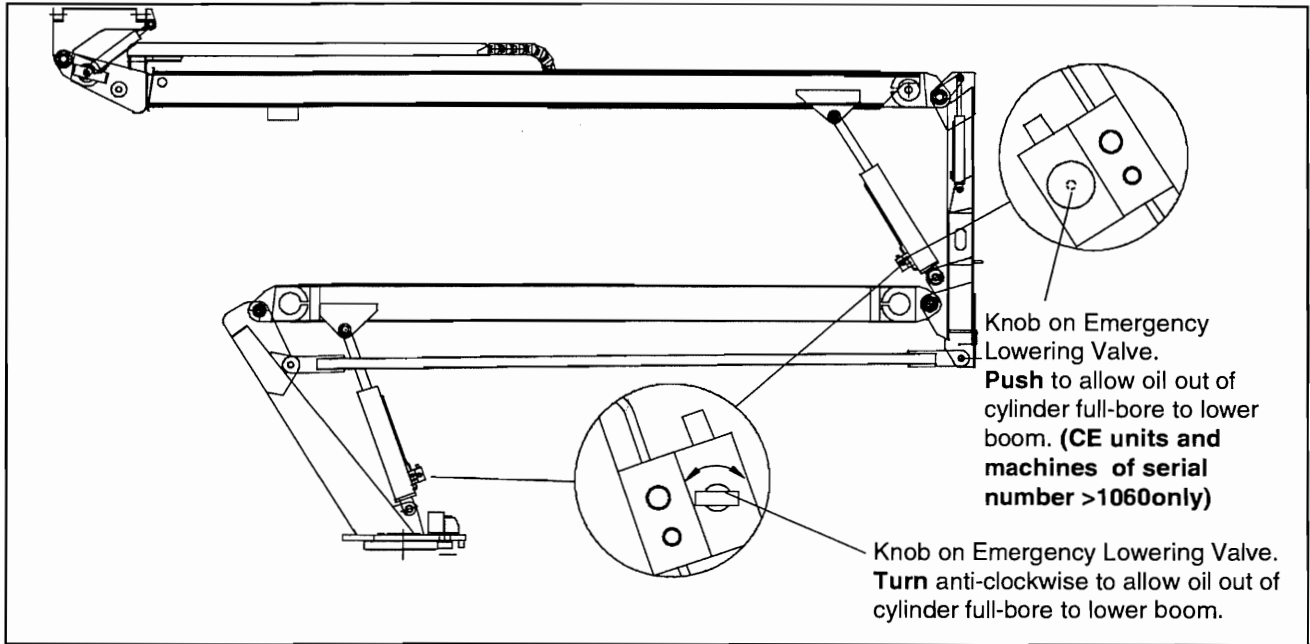

Figure 3-3: Emergency lowering Valve

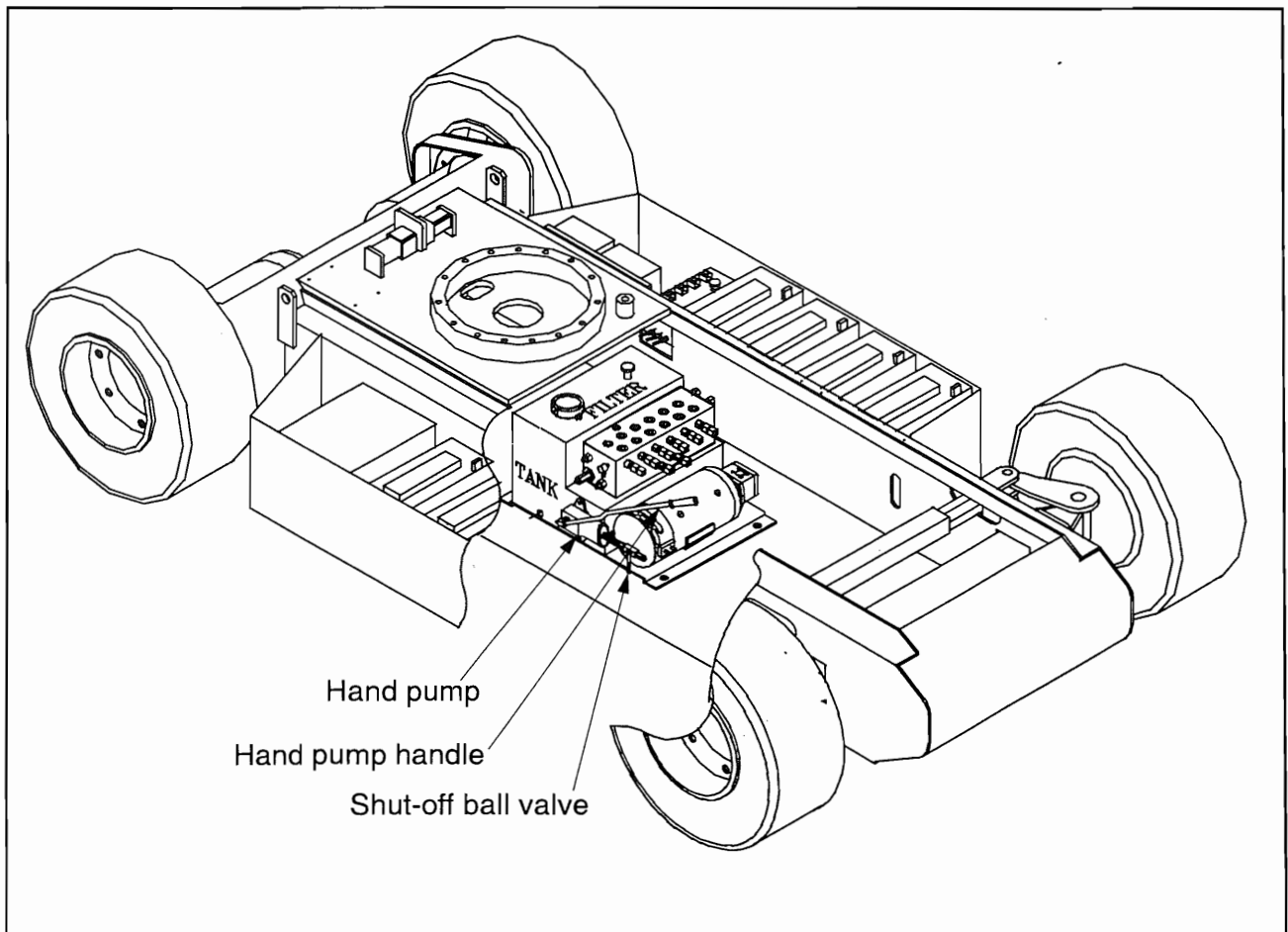

Figure 3-4: Manual Tele Retraction Hand Pump

NOTES

4.0 Introduction

This section contains instructions for the maintenance of the SP37 Series Work Platform. Procedures for scheduled maintenance and repair/removal are included.

Referring to *Section 3 and Section 6* will aid in understanding the operation and function of the various components and systems of the SP37 Series Work Platform and help in diagnosing and repair of the machine.

TOOLS REQUIRED

The following is a list of items that are required to perform certain maintenance procedures.

- 1 x Multi-meter capable of reading Voltage, Ohms and Amps.
- 1 x Pressure Gauge - Range (0 - 1000 P.S.I.)
- 1 x Pressure Gauge - Range (0 - 3000 P.S.I.)



We recommend:

- 1 x 57128-000 Calibrator - A test and analysis instrument for the D.C. motor Control Unit.



4.1 Preventative Maintenance (Table 4-1)

The complete inspection consists of periodic visual and operational checks, together with all necessary minor adjustments to assure proper performance. Daily inspection will prevent abnormal wear and prolong the life of all systems. The inspection and maintenance schedule is to be performed at regular intervals.

Inspection and maintenance shall be performed by personnel who are trained and familiar with mechanical and electrical procedures. Complete descriptions of the procedures are in the text following the table.

 WARNING 
Before performing preventative maintenance familiarise yourself with the operation of the machine. Never perform maintenance on a machine when it is in the elevated position.

The Preventative Maintenance table has been designed to be used for machine service and maintenance repair. **Please copy the following page and use this table as a checklist when inspecting a machine for service.**

 WARNING 
To ensure safe electrical maintenance the following must be carried out: On the negative terminal of the battery pack, a green/yellow earth cable is connected between that terminal and the chassis (at the motor control panel assembly mounting bolt). Use a 13mm spanner to open the nut and so disconnect the cable before any electrical work is carried out on the machine. Ensure that you reconnect when you are finished. * CE Machines only

Preventative Maintenance Table Key

Interval

Daily=each shift or every day
 50h/30d= every 50 hours or 30 days
 250h/6m=every 250 hours or 6 months
 500h/1y=every 500 hours or 1 year
 1000h/2y=every 1000 hours or 2 years

Y=Yes/Acceptable
N=No/Not Acceptable
R=Repaired/Acceptable



Preventative Maintenance Report

Date:	
Owner:	
V.I.N No.:	Serial No.:
Serviced By:	
Service Interval:	

Table 4-1: Preventative Maintenance

COMPONENT	INSPECTION OR SERVICES	INTERVAL	Y	N	R
Battery System	Check electrolyte level Check battery cable condition Charge batteries Check charger condition & operation Check specific gravity Clean exterior Clean terminals	Daily Daily Daily Daily 50h/30d 250h/6m 250h/6m			
Hydraulic Oil	Check oil level Change filter Drain and replace oil (ISO #46)	Daily 250h/6m 500h/1y			
Hydraulic System	Check for leaks Check hose connections Check for exterior wear	Daily 50h/30d 50h/30d			
Emergency Hydraulic System	Open the emergency lowering valves and check for proper operation.	Daily			
Control Joystick	Check condition and operation	Daily			
Electrical Control Cables	Check the exterior of the cables for pinching, binding or wear	Daily			
Platform Cage	Check welds for cracks Check that securing bolts are tightened Check condition of floor Check drop bar on cage entrance	Daily			
Hydraulic Pump	Check for hose fitting leaks Wipe clean Check for leaks at mating surfaces Check mounting bolts for proper torque	Daily 50h/30d 50h/30d 50h/30d			
Elevating Assembly	Inspect for structural cracks Check hoses for pinch or rubbing points Check pivot bearings for wear Check all pivot pin retaining plates and clips Check elevating assembly structure for bending Check function of all lights and indicators on the tail board assembly	Daily Daily 50h/30d 50h/30d 250h/6m 50h/30d			
Steering system	Lubricate all pivot pins Check steering cylinder for leaks Check hardware and fittings for proper security	250h/6m 50h/30d 250h/6m			
Chassis Assembly	Inspect for structural cracks Check hoses for pinch or rubbing points Check pivot bearings for wear Check all pivot pin retaining plates and clips Check Tyres for damage Check security of wheel motor gearbox bolts Torque wheel nuts to 80Nm (59 lb. ft)	Daily Daily 50h/30d 50h/30d 50h/30d 250h/6m 50h/30d			
Entire Unit	Function check Emergency stop switches at control boxes Perform pre-operation inspection Check for and repair collision damage Lubricate See Section 4.4 Check fasteners for proper torque Check for corrosion-remove and repaint	Daily Daily Daily 50h/30d 250h/6m 250h/6m			
Labels	Check for peeling, missing, or unreadable labels & replace	Daily			

4.2 Maintenance on Elevated platform

 WARNING 
<p>BEFORE entering Elevating Assembly while performing maintenance on work platform, while elevated, ensure that Elevating Assembly is properly blocked and/or secured by suitable crantage of adequate capacity.</p> <p>DO NOT stand in Elevating Assembly area while installing or removing blocking or cranes.</p>

4.3 Battery Maintenance



Electrical energy for the motor is supplied by eight 6-volt batteries wired in series for 48 volts DC. Proper care and maintenance of the batteries and the motor will ensure maximum performance from the work platform.

 WARNING 
<p>Hazard of explosive gas mixture. Keep sparks, flame and smoking materials away from batteries.</p> <p>Always wear safety glasses when working with batteries.</p> <p>Battery fluid is highly corrosive. Rinse away any spilled fluid thoroughly with clean water.</p> <p>Be extra cautious to reduce risk of dropping a metal tool onto battery. It may spark or short circuit battery and may cause explosion.</p> <p>Always replace batteries with UpRight batteries or manufacturer approved replacements weighing 62lbs (28 Kg) each.</p>

Limit use of new batteries for first five cycles. New batteries are not capable of their rated output until they have been charged and discharged approximately 10 - 15 times.

BATTERY INSPECTION AND CLEANING

Check battery fluid level daily, especially if work platform is being used in a warm, dry climate. If required add distilled water only. Use of tap water with high mineral content will shorten battery life.

 CAUTION 
<p>If battery water level is not maintained, batteries will not fully charge, creating a low discharge rate that will damage motor/pump unit and void warranty.</p>

Batteries should be inspected periodically for signs of cracks in the cases, electrolyte leakage and corrosion of the terminals. Inspect cables for worn spots or breaks in the insulation and for broken cable terminals.

Clean batteries that show signs of corrosion of the terminals or onto which electrolyte has overflowed during charging. Use a baking soda solution to clean the batteries, taking care not to get the solution inside the cells. Rinse thoroughly with clear water. Clean battery and cable contact surfaces to a bright metal finish whenever a cable is removed.

BATTERY CHARGING (Figure 4-2)

Charge batteries at end of each work shift or sooner if batteries have been discharged.

⚠ CAUTION ⚠

Charge batteries in a well ventilated area.
Do not charge batteries when the work platform is in an area containing sparks or flames. Permanent damage to batteries will result if batteries are not immediately recharged after discharging.
Never leave charger operating unattended for more than two days.
Never disconnect cables from batteries when charger is operating.
Keep charger dry.

1. Check battery fluid level. If electrolyte level is lower than 10mm above plates add distilled water only.
2. Connect extension cord (1.5mm² conductor minimum and 15m in length maximum) to the charger plug. Connect the other end of extension cord to properly grounded outlet of proper voltage and frequency.
3. Charger turns on automatically after a short delay and runs through a self diagnostic check. All 5 LEDs will flash 3 times and then each LED will flash once. The yellow LED (charger on) and the red LED (incomplete) will then turn on. This is the start of the battery charging.
4. The yellow LED (80% charge) will illuminate when the batteries are 80% charged.
5. Finally the green LED will illuminate when the batteries are fully charged. This should take approximately 14 to 16 hours depending on the level of discharge of the batteries before charging.
- 6 The red LED (abnormal cycle) will illuminate in the following conditions:
 - (a) If the A.C. plug is removed from the power source during charging.
 - (b) If after 16 hours the batteries are not charged due to the fact that the batteries were 'too big' to be charged i.e. higher voltage or ampere/hour rating than is recommended.
 - (c) If the volt/cell is less than 2.5v at the end of the charge cycle.

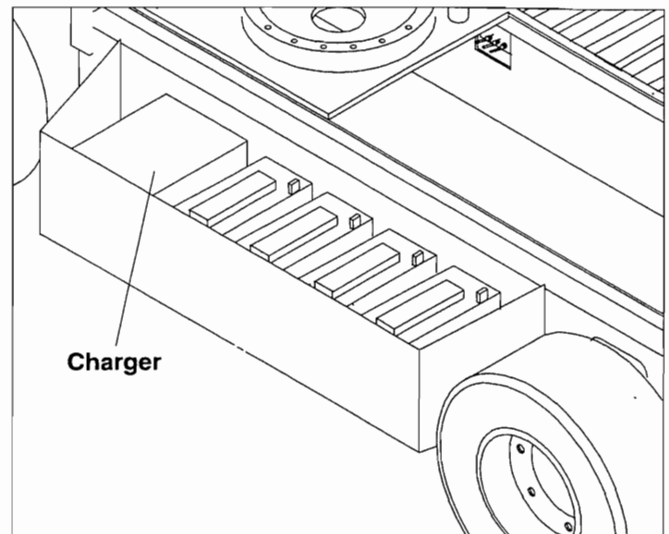

Figure 4-2a: Battery Charger Location

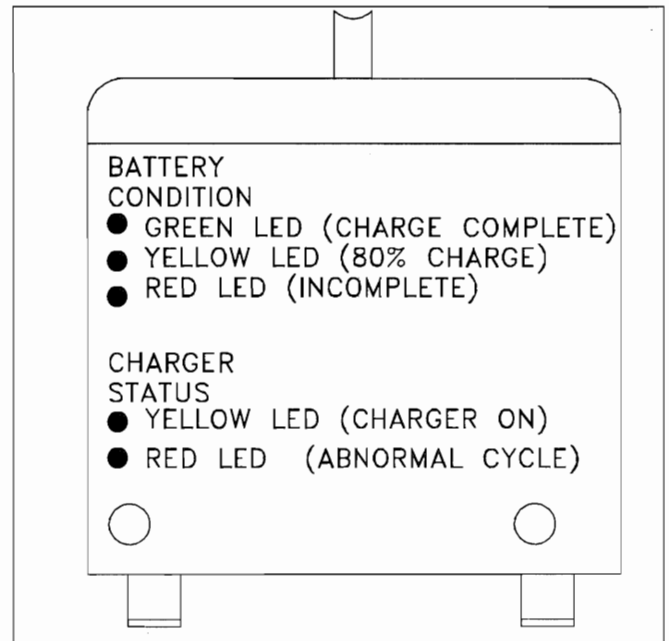

Figure 4-2b: Battery Charger Indicators

CELL FORMING

The plates in the new battery cells take approximately 10 to 15 cycles (charge and discharge) to 'form' and operate at full capacity.

During this period the batteries should not be discharged excessively.

Excessive discharge can cause polarity reversal of individual cells resulting in complete failure shortly thereafter. Limited use of new batteries will minimise the chance of cell reversal.

Note: Charging time will be longer when the batteries are new.

4.4 Lubrication

Refer to Figure 4-3 for location of items that require lubrication service.

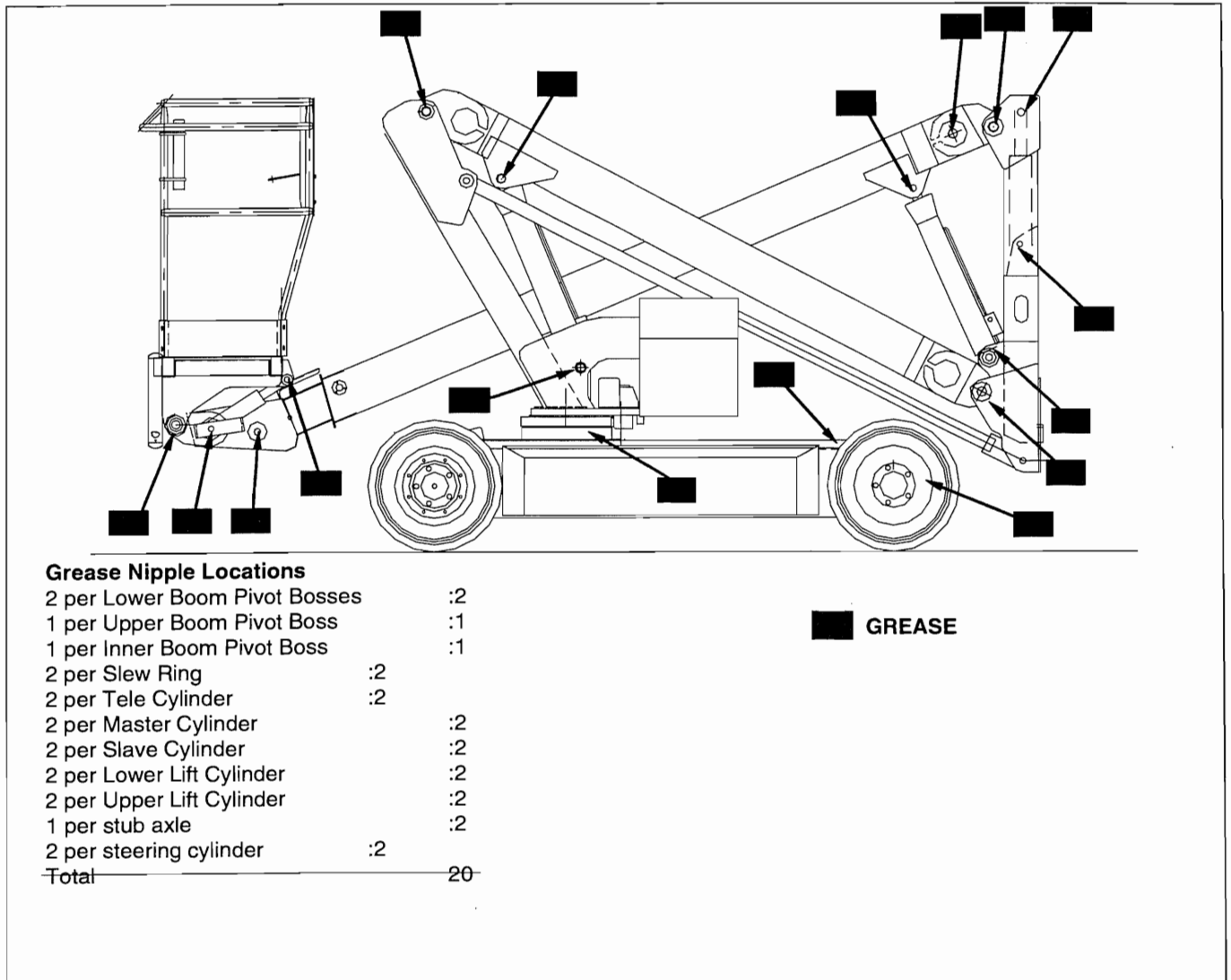

Figure: 4-3 Lubrication Points

HYDRAULIC OIL TANK AND FILTER (Figure 4-4)

Fluid Level

With platform fully lowered, oil should be visible on the dipstick, if not fill the tank until oil registers on the dipstick. **DO NOT** fill above the upper line or when the platform is elevated.

Oil and Filter Replacement

1. Operate the platform for 10-15 minutes to bring the hydraulic oil up to normal operating temperature.

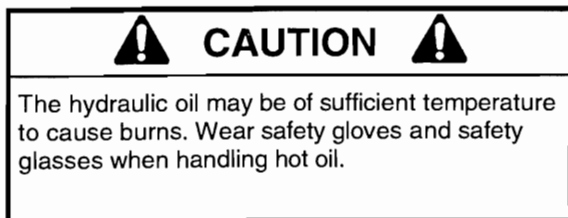

2. Provide a suitable container to catch the drained oil. Hydraulic tank has a capacity of 25 Litres.
3. Remove the drain plug on the lower side of the tank and allow all oil to drain
4. Clean the magnetic drain plug and reinstall.
5. Disconnect return hose and hose fitting from inlet port of hydraulic return filter. Loosen and remove filter cover retaining bolts. Remove filter (10 micron) assembly. Replace with new filter.
6. Fill the hydraulic reservoir with hydraulic oil (see Section 1-2) checking level with dipstick.

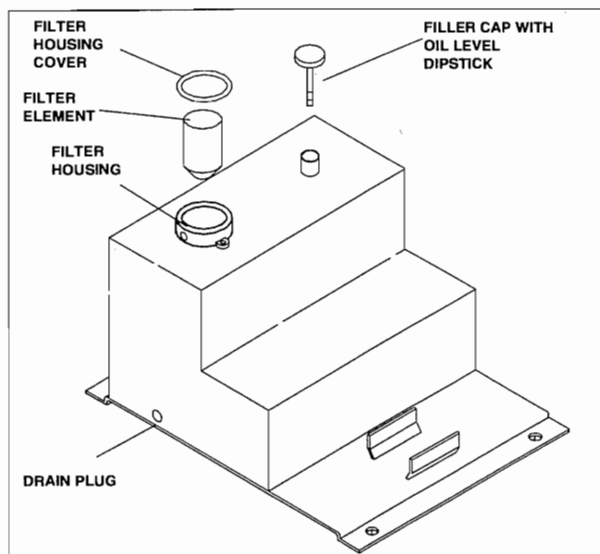
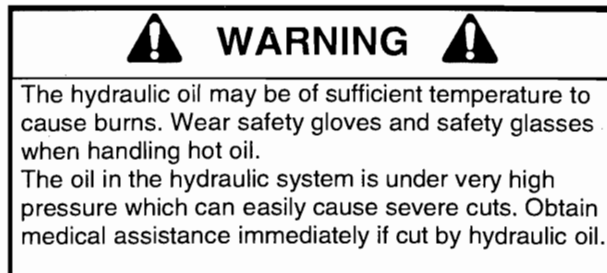

Figure 4-4: Oil & Filter Replacement

4.5 Setting Hydraulic Pressures (Figure 4-5)

Check the hydraulic pressures whenever the pump, manifold or relief valve have been serviced or replaced.



MAIN RELIEF VALVE (Figure 4-5)

1. Operate the hydraulic system for 10-15 minutes to warm the oil.
2. Remove the cover from the chassis body.
3. Insert pressure gauge into high pressure gauge port marked 'TP' on side face of main manifold block.
4. Loosen locknut on main relief valve and turn adjusting screw counter clockwise two full turns.
5. Operate telescope-in function switch at lower controls and keep it activated.
6. Slowly turn the main relief valve adjusting screw clockwise until the pressure gauge reads 145 Bar pressure. (2100 P.S.I.)
7. Release Telescope-in switch.
8. Tighten locknut on main relief valve while holding the adjusting screw in position.

SLEW CROSS-LINE RELIEF VALVES (Figure 4-5)

1. Operate the hydraulic system for 10-15 minutes to warm the oil.
2. Remove the cover from the chassis body.
3. Insert pressure gauge into high pressure gauge port marked 'PT' on side face of main manifold block.
4. Loosen locknuts on both cross-line relief valves and turn adjusting screws counter clockwise two full turns.
5. Operate slew function from lower controls and rotate elevating assembly through approx. 180° until the slew stop prevents further rotation.
6. Slowly turn the cross-line relief valve adjusting screw clockwise until the pressure gauge reads 50 Bar (725 p.s.i.) pressure.
7. Now operate the slew function in the opposite direction through approx. 360° until the slew stop prevents further rotation.
8. Slowly turn the remaining cross-line relief valve adjusting screw clockwise until the pressure gauge reads 50 Bar (725 p.s.i.) pressure.
9. Tighten the locknuts on both cross-line relief valves while holding the adjusting screws in position.

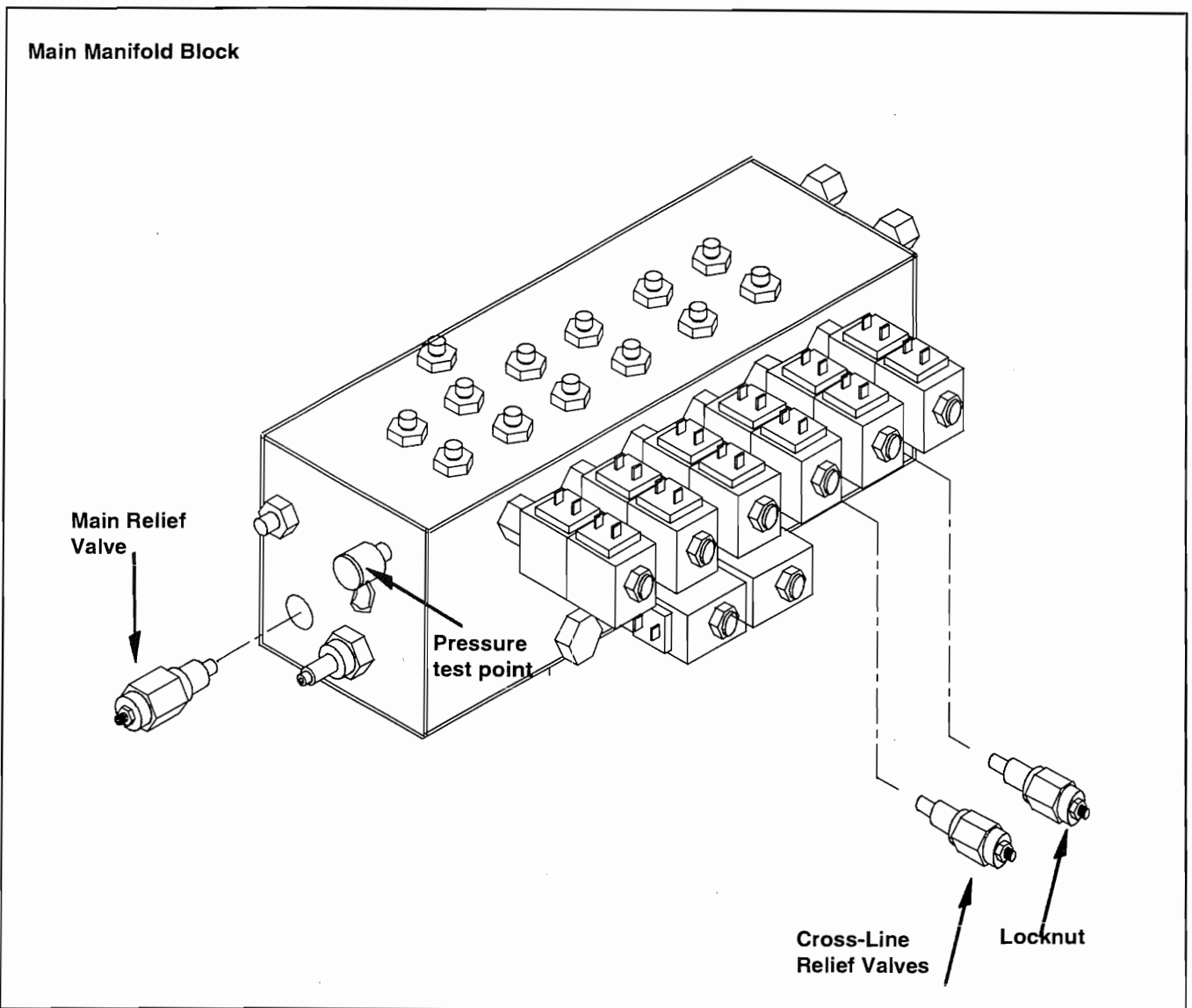

Figure 4-5 Main Manifold Block

4.6 Switch Adjustments

SLEW CUT-OUT LIMIT SWITCH

Function: The purpose of this limit switch is to prevent the operator from slewing while the lower boom tension bars are between the drive wheels thus preventing accidental damage to them. It does this by breaking the slew signal from the upper or lower controls while the tension bars are between the wheels.

Location: The switch is located on the first post .

Adjustment: To adjust the switch loosen the lever clamping nut and rotate the lever. Tighten the lever clamping nut. The lever is actuated by the lower boom, as it descends. The Normally Closed contacts of the switch should open when the lower boom is at an angle such that the tension bars near the second post are above the top of the drive wheels and will not strike them.

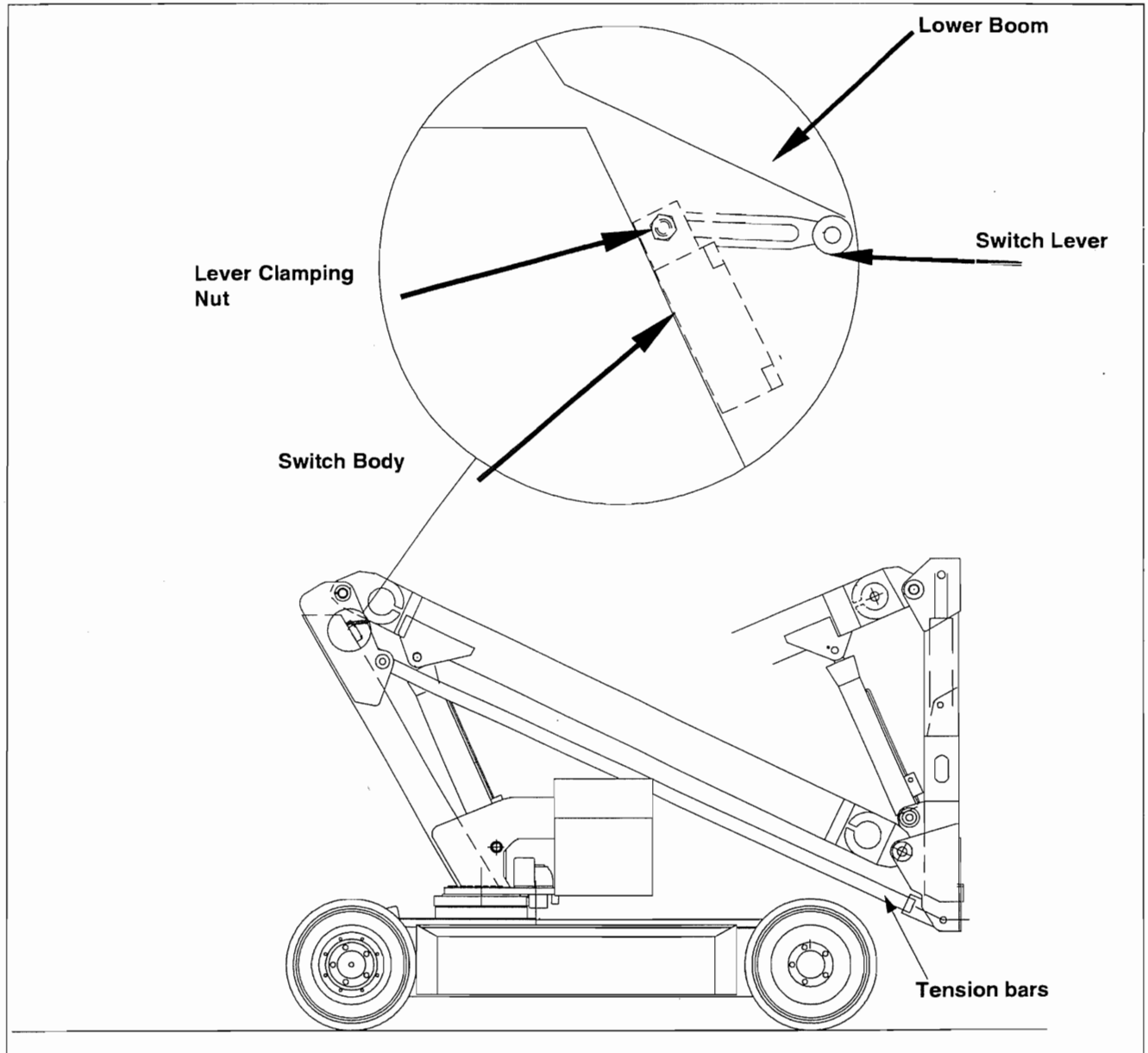

Figure 4-6: Slew Cut-out Limit Switch

4.6 Switch Adjustments (Contd...)

BOOM REST LIMIT SWITCH

Function: This limit switch is activated when the booms are fully stowed and the lower boom is sitting in the boom rest. Fast drive speed is available when this switch is activated. When the boom leaves the boom rest the Normally Open contacts of the limit switch open and the boom stowed signal to the traction motor controller is broken and restricted drive speed is restored.

NOTE: CE Machines are fitted with a different switch that has an extra Normally Open contact. This N.O. contact breaks the levelling signal to the pump motor controller when the booms are off the boom rest. This allows cage levelling to take place only when the booms are stowed.

Location: The switch is located on the 1st post assembly.

Adjustment:

The switch should be activated when the lower boom sits in the boom rest. The lever is non-adjustable, but should be checked for freedom of movement and kept clean from dirt and other contaminants that might affect its free movement.

NOTE: The CE switch has an adjustable lever similar to the slew cut-out limit switch. This lever should be adjusted to activate the N.O. contacts when the booms are stowed on the boom rest.

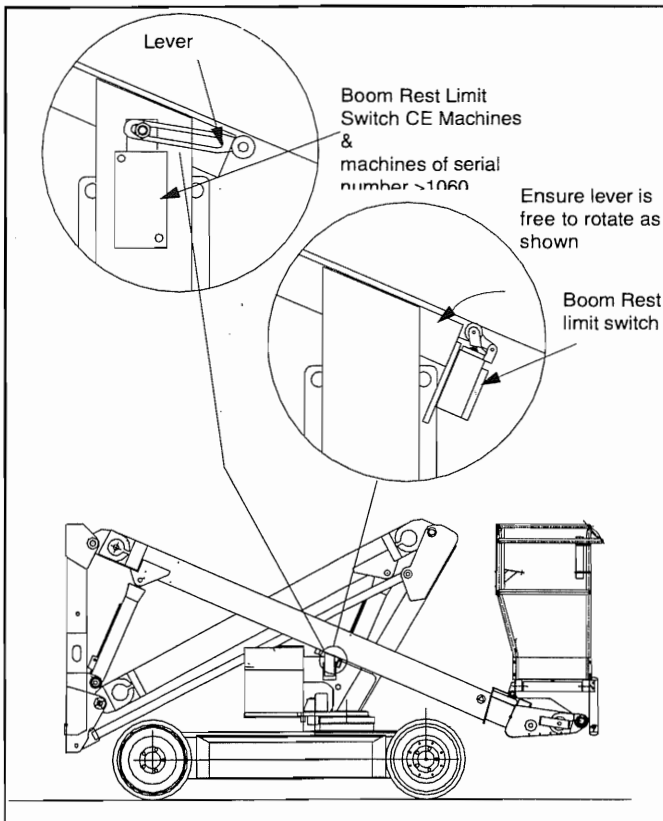

Figure 4-7: Boom Rest Limit Switch

8m CUT-OUT LIMIT SWITCH (CE Units only)

Function: This limit switch is used to detect when the cage reaches 8m height above the ground and prevents drive at this point. The roller part of the lever rests with spring force on the pivot boss of the upper boom. There is a cam on this boss which lifts the roller head as the boom rises and activates the switch opening the normally closed contacts.

The cage height of 8m is with the tele boom fully extended, the lower boom fully elevated and the upper boom at an angle which puts the cage floor 8m above the ground.

Note: the drive cut-out will occur at lower cage heights depending on the height of the lower boom and the extension of the tele boom.

Location: The switch is located on the 2nd post assembly.

Adjustment: To adjust the switch loosen the lever clamping nut. Rotate the central shaft with a screw driver against the internal spring force. Create enough spring force to allow the lever to push gently on the boom boss, but not to much as to activate the contacts before the switch rises up on the cam. Tighten the lever clamping nut and test the cage floor height when the drive signal is broken. If the cage is above 8m adjust the switch lever.

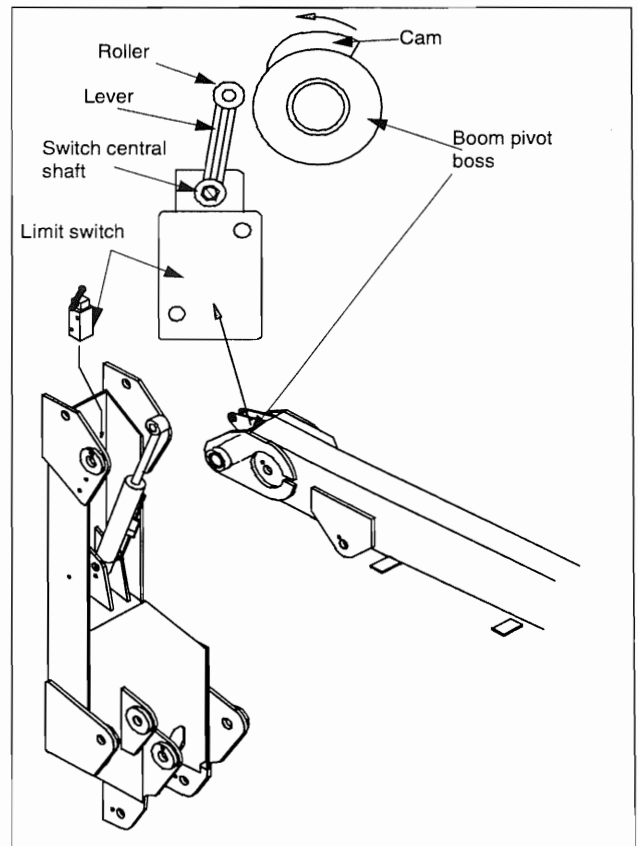

Figure 4-8: 8m Cut-out Limit Switch

4.7 Hydraulic Manifold

Though it is not necessary to remove the manifold to perform all maintenance procedures, a determination should be made as to whether or not the manifold should be removed before maintenance procedures begin.

REMOVAL

1. Remove battery ground cable.
2. Remove cover from chassis body.
3. Tag and disconnect the solenoid valve leads from the solenoids.
4. Tag, disconnect and plug hydraulic hoses.
5. Remove securing bolts that hold manifold block to hydraulic reservoir.
6. Remove manifold block.

DISASSEMBLY

NOTE: Mark all components as they are removed so as not to confuse their location during assembly. Refer to Figure 4-9 often to aid in disassembly and assembly.

1. Remove coils from solenoid valves.
2. Remove solenoid valves and cartridge valves.
3. Remove fittings and bonded washers.
4. Remove spool housings and spools.

CLEANING AND INSPECTION

1. Wash the manifold in cleaning solvent to remove built up contaminants and then blow out all passages with **clean** compressed air.
2. Inspect the manifold for cracks, thread damage and scoring where O-rings seal against internal and external surfaces.
3. Wash and dry each component and check for thread damage, torn or cracked O-rings and proper operation.
4. Replace parts and O-rings found unserviceable.

ASSEMBLY

Note: Lubricate all O-rings before installation to prevent damage to O-rings.

1. Install fittings and bonded seals.
2. Install relief valves and solenoid valves.

Note: Torque cartridge relief valves to 45NM.
Torque solenoid spool cartridges to 20NM
Torque coil retaining nuts to 3.4NM

INSTALLATION

1. Attach manifold assembly to reservoir with nuts and washers.
2. Connect hydraulic hoses to their destinations on the manifold block.
3. Connect solenoid leads to their correct coils.
4. Operate each hydraulic function and check for proper function and leaks.

- 1. Valve Block
- 2. Spool Assembly, (including O-Rings)
- 3. Coil
- 4. Locking Nut
- 5. Relief Valve (Slew)
- 6. Relief Valve (Main)

- 7. Fitting ,Straight
- 8. Pressure reducer valve
- 9 Fitting, Pressure Test Point
- 10. Check valve
- 11. Bonded seal

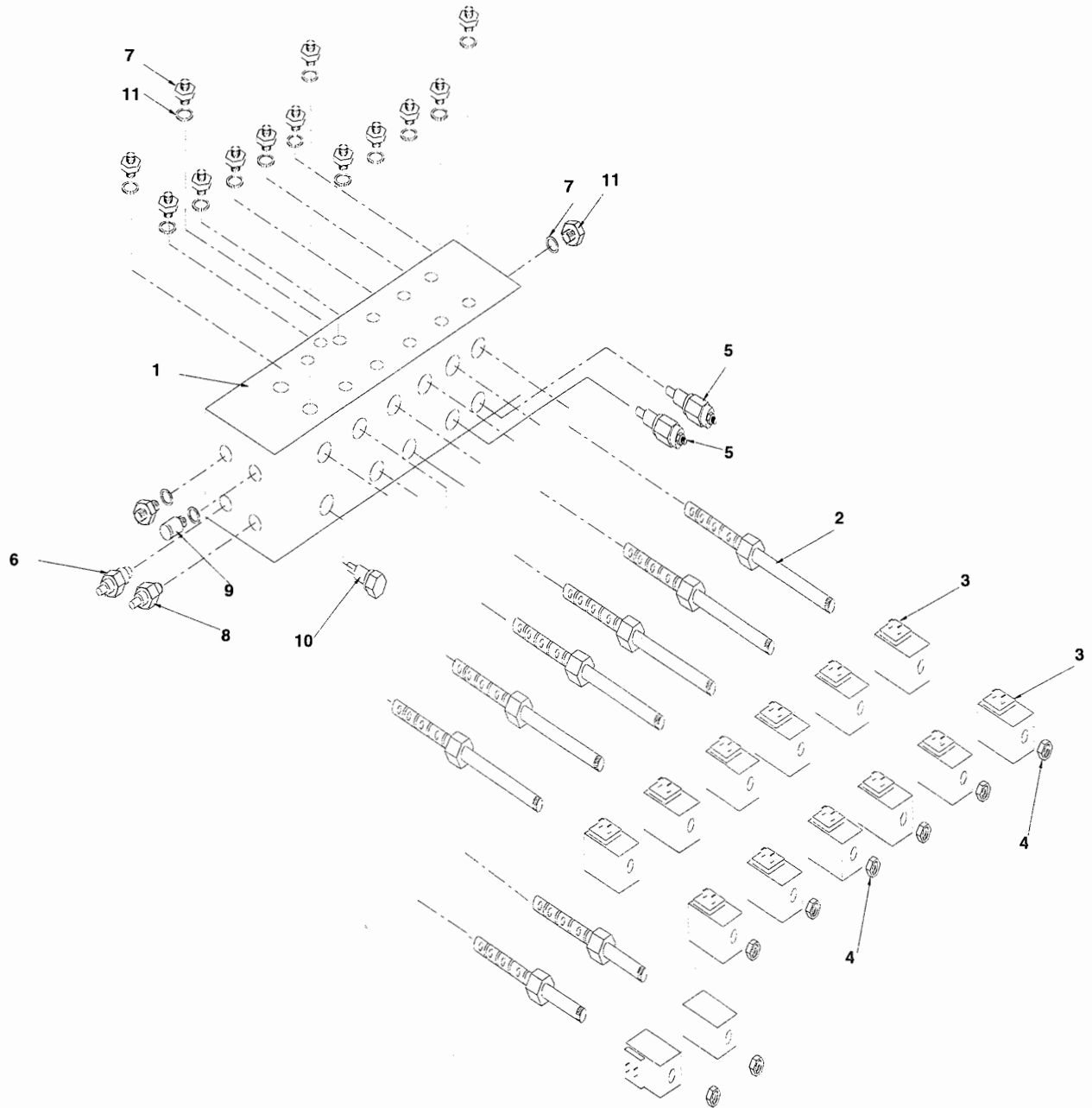

Figure 4-9: Main manifold Block

4.8 Hydraulic Pump (Figure 4-10)

REMOVAL

NOTE: If the hydraulic reservoir has not been drained, suitable means for plugging the hoses should be provided to prevent excessive fluid loss.

1. Mark, disconnect and plug hose assemblies.
2. Loosen the capscrews and remove the pump assembly from the motor.

INSTALLATION

1. Lubricate the pump shaft with general purpose grease and attach the pump to the motor with the capscrews.
2. Using a criss-cross pattern torque each capscrew a little at a time until all the capscrews are torqued to 20 ft.lbs. (27 N-m).
3. Unplug and reconnect the hydraulic hoses.
4. Check the oil level in the hydraulic tank before operating the work platform.

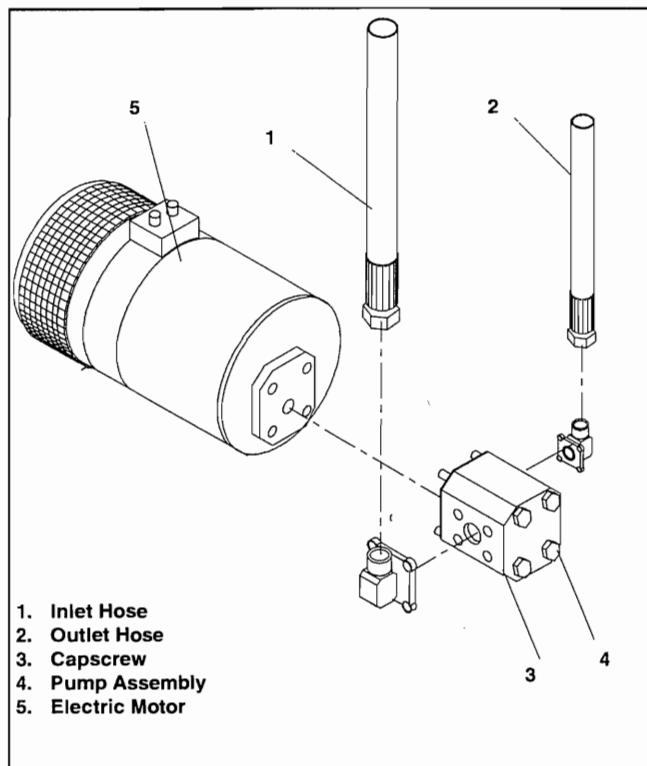

Figure 4-10: Hydraulic Pump

REMOVAL

SP37 Work Platform

4.9 Hydraulic Cylinders

A: Slave Levelling Cylinder

NOTE: Removal of the slave cylinder requires the cage to be held in position by suitable support slings or by another person.

1. Disconnect both hoses and plug ends to avoid excessive oil spillage. Note which hose goes to which port.
2. Remove lock plate securing bolt and spring washer from both the rod end pin and body end pin.
3. Remove lock plates.
4. Hold cage assembly in position and knock out rod end pin and body end pin.
5. Remove cylinder.

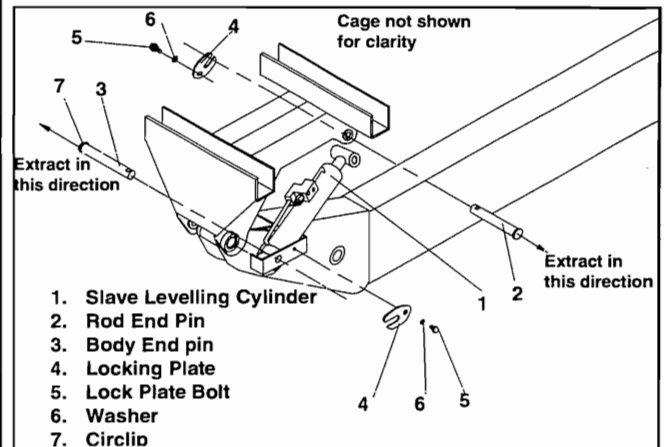

Figure 4-11: Slave Levelling Cylinder

DISASSEMBLY, CLEANING AND INSPECTION, REASSEMBLY

All the cylinders are similar in their construction and the disassembly, cleaning and inspection and reassembly is dealt with in Section 4-10.

INSTALLATION

Note: before installing Slave Cylinder check cylinder pins and bearings for wear and replace if necessary.

1. Lift the cylinder into place and insert the body end pin in through the cylinder and boom.
Note: take care in aligning the pin in the holes so that the pin can be pushed in by hand. If the pin and holes are not properly aligned and the pin is forced in, the bushings will be damaged.
2. Line the cage cradle holes up with the cylinder rod hole and insert the rod end pin.
3. Slide both locking plates into the groves on the pins and secure with the bolts and washers.
4. Test with weight at rated platform load to check system operation.

B: Master Levelling Cylinder

1. Disconnect the 4 hoses and plug ends to avoid excessive oil spillage. Note which hose goes to which port.
2. Remove lock plate securing bolt and spring washer from both the rod end pin and body end pin.
3. Remove lock plates.
4. Holding the cylinder securely. Knock out both the rod end and body end pins.
5. Remove the cylinder.

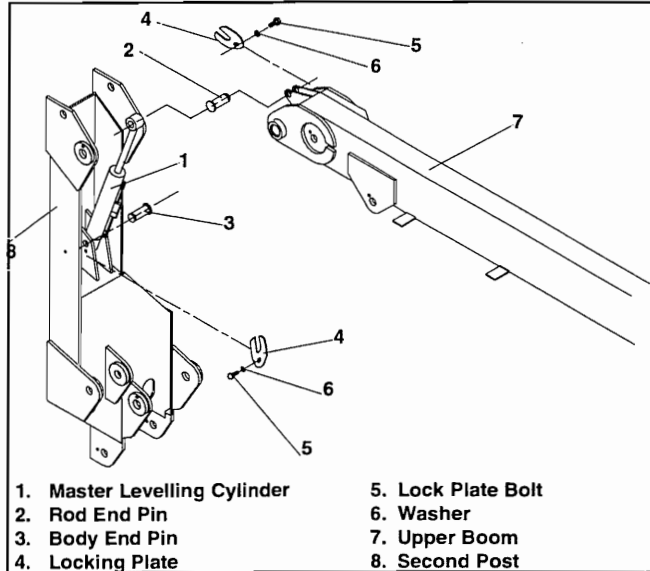

Figure 4-12: Master Levelling Cylinder

DISASSEMBLY, CLEANING AND INSPECTION, REASSEMBLY

See Section 4-10.

INSTALLATION

Note: before installing Master Cylinder check cylinder pins and bearings for wear and replace if necessary.

1. Lift the cylinder into place and insert the body end pin in through the cylinder and Second Post Anchors.

Note: take care in aligning the pin in the holes so that the pin can be pushed in by hand. If the pin and holes are not properly aligned and the pin is forced in, the bushings will be damaged.

2. Line the Upper Boom Anchor holes up with the cylinder rod hole and insert the rod end pin. (Note: To move the cylinder rod for aligning the holes the overcentre cartridges must be removed from the block on the cylinder body or alternatively the Upper Lift Cylinder can be used to raise and lower the Upper Boom)
3. Slide both locking plates into the groves on the pins and secure with the bolts and washers.
4. Reconnect the hoses to their correct ports.
5. **Test with weight at rated platform load to check system operation.**

C: Telescopic Cylinder

1. Set the machine up on level ground.
2. Raise the upper boom to just below horizontal.
3. Disconnect the two hoses from the cylinder body and plug. Note which hose goes to which port.
4. Remove the lock plate securing bolt and spring washer from both the inner and outer upper boom.
5. Remove both lock plates.
6. The tele cylinder can now be pulled out of both booms. Note: the cylinder will require two people to lift it out due to its length and weight.

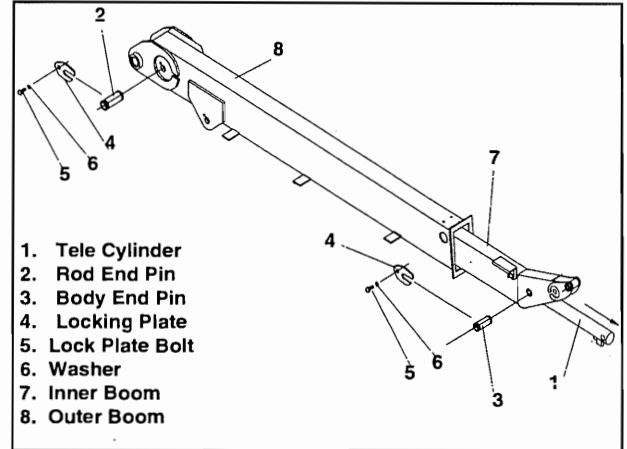

Figure 4-13: Tele Cylinder

DISASSEMBLY, CLEANING AND INSPECTION, REASSEMBLY

See Section 4-10.

INSTALLATION

Note: before installing Tele Cylinder check cylinder pins and bearings for wear and replace if necessary

1. Lift the cylinder into place and slide it into the front end of the Inner Boom.
2. Insert a metal bar (e.g. a screw driver) into one of the pin holes in the Outer Boom and into the rod-end pivot.
3. Lift the rod end up to align the holes on the cylinder and the Outer boom.

Note: take care in aligning the pin in the holes so that the pin can be pushed in by hand. If the pin and holes are not properly aligned and the pin is forced in, the bushings will be damaged.

4. Insert the rod end pin through the boom and cylinder and secure the locking plate to the pin end with the bolt and washer.
5. Repeat steps 2 to 4 at the body end.
6. Reconnect the hoses to their correct ports.
7. **Test with weight at rated platform load to check system operation.**

D: Lower Lift Cylinder

NOTE: Due to the force on the pins caused by the weight of the booms, it is generally necessary to use a sling and overhead crane of suitable capacity to assist in the removal of the cylinder pins.

1. Set the machine up on level ground.
2. Securely attach a sling to the second post and to an overhead crane.
3. Disconnect the two hoses from the cylinder body and plug. Note which hose goes to which port.
4. Remove lock plate securing bolt and spring washer from both the rod end pin and body end pin.
5. Remove the lock plates.
6. Take up the slack on the sling to remove the weight of the booms on the rod end pin.
7. Knock the rod end pin out pin out.
8. Knock the body end pin out.
9. Remove cylinder.

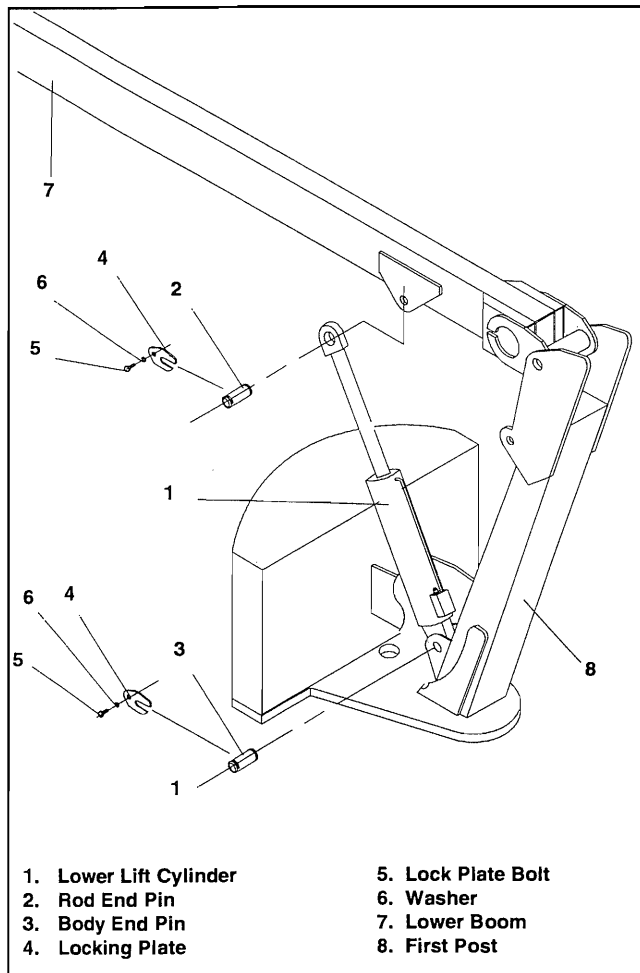

Figure 4-14: Lower Lift Cylinder

DISASSEMBLY, CLEANING AND INSPECTION, REASSEMBLY

See Section 4-10.

INSTALLATION

Note: before installing Lower Lift Cylinder check cylinder pins and bearings for wear and replace if necessary.

1. Lift the cylinder into place and insert the body end pin in through the cylinder and First Post Anchors.

Note: take care in aligning the pin in the holes so that the pin can be pushed in by hand. If the pin and holes are not properly aligned and the pin is forced in, the bushings will be damaged.

2. Line the Lower Boom Anchor holes up with the cylinder rod hole and insert the rod end pin. (Note: To align the holes use an overhead crane and sling of suitable capacity firmly secured to the second post. This should be used to raise and lower the Lower Boom)
3. Slide both locking plates into the grooves on the pins and secure with the bolts and washers.
4. Reconnect the hoses to their correct ports.
5. **Test with weight at rated platform load to check system operation.**

E: Upper Lift Cylinder

Follow the same procedure as with the lower lift cylinder but use the sling on the upper boom at the cage end.

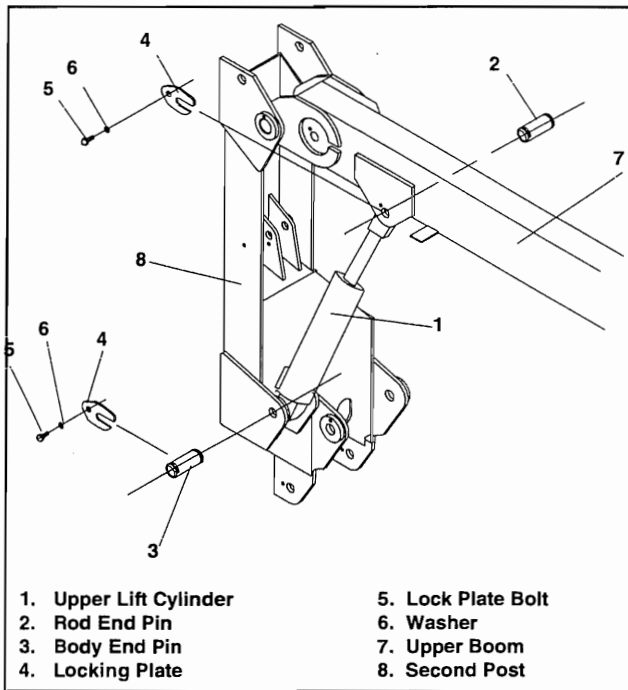

Figure 4-15: Upper Lift Cylinder

DISASSEMBLY, CLEANING AND INSPECTION, REASSEMBLY

See Section 4-10.

INSTALLATION

Note: before installing Upper Lift Cylinder check cylinder pins and bearings for wear and replace if necessary.

1. Lift the cylinder into place and insert the body end pin in through the cylinder and Second Post Anchors.

Note: take care in aligning the pin in the holes so that the pin can be pushed in by hand. If the pin and holes are not properly aligned and the pin is forced in, the bushings will be damaged.

2. Line the Upper Boom Anchor holes up with the cylinder rod hole and insert the rod end pin. (Note: To align the holes use an overhead crane and sling of suitable capacity firmly secured to the Upper Boom at the cage end. This should be used to raise and lower the Upper Boom).
3. Slide both locking plates into the groves on the pins and secure with the bolts and washers.
4. Reconnect the hoses to their correct ports.
5. **Test with weight at rated platform load to check system operation.**

F: Steering Cylinder

1. Straighten drive wheels.
2. Disconnect the hoses from the cylinder and plug to avoid excessive oil spillage. Note which hoses go to which ports.
3. Remove the securing bolts and washers from the cylinder lock plates.
4. Remove the lock plates.
5. Remove the body end pin.
6. Remove the rod end pin.
7. Remove the cylinder.

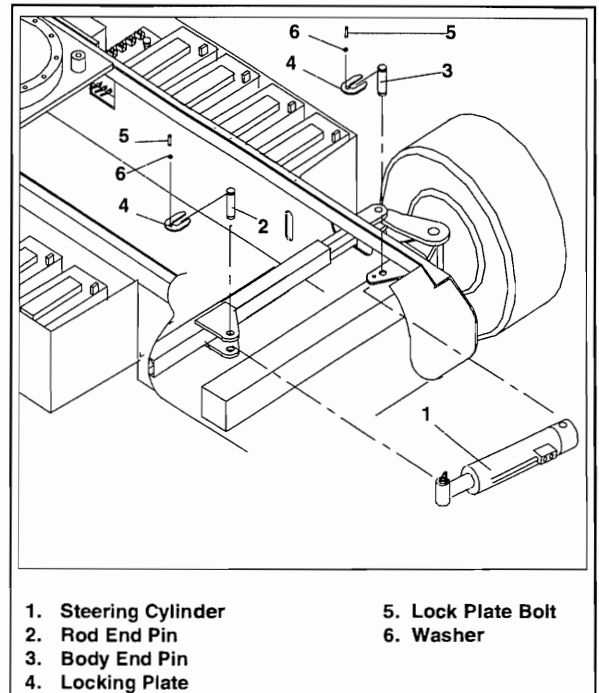

Figure 4-16: Steering Cylinder

DISASSEMBLY, CLEANING AND INSPECTION, REASSEMBLY

See Section 4-10.

INSTALLATION

Note: before installing Steering Cylinder check cylinder pins and bearings for wear and replace if necessary.

1. Installation is the reverse of removal (above)

Note: take care in aligning the pin in the holes so that the pin can be pushed in by hand. If the pin and hole are not properly aligned and the pin is forced in, the bushings will be damaged.

2. **Test with weight at rated platform load to check system operation**

4.10 Disassembly, Cleaning and Inspection and Assembly of Hydraulic cylinders

Note: The disassembly, cleaning and inspection and assembly for all the cylinders is basically the same.

DISSASSEMBLY OF HYDRAULIC CYLINDERS

Note: Prepare a clean work area on which to service the internal parts.

1. Remove fittings, Pilot operated check valve cartridges and overcentre valve cartridges from the cylinder blocks.
2. Bend up tab on tab washer (if applicable).
3. Unscrew end cap and remove from cylinder body with rod and piston.
4. Unscrew the piston locknut from the rod and remove the piston head and the end cap.

Note: Some piston locknuts are fitted with a roll pin and grub screw which must be removed before unscrewing the locknut.

5. Remove all seals from the end cap (i.e. wiper, shaft seal, O-ring, rod seal, end cap gland and PTFE seal) and disregard.
6. Remove all seals from piston head (i.e. piston O-ring and piston seal) and disregard.

CLEANING AND INSPECTION

1. Clean all metal parts in solvent and blow dry with filtered compressed air.
2. Check all threaded parts for stripped or damaged threads.
3. Check the bearing surfaces inside of the end cap, outer edge surface of the piston, inside the cylinder body and the rod for signs of scoring or excessive wear.
4. Replace any parts found unserviceable.
5. Discard all seals.
6. Examine all cartridge valves for wear on threads and damage to O-rings.

ASSEMBLY

1. Lubricate and install a new complete set of seals on both the end cap and piston.
2. Slide the end cap onto the rod (with the tab washer where applicable) and then the piston head.
3. Screw on the piston locknut (fitting roll pin and grub screw where applicable).
4. Lubricate the entire assembly's seals and slide the piston into the cylinder body.
5. Screw end cap onto end of cylinder body.
6. Bend down tab on tab washer.
7. Insert all cartridge valves and fittings into the cylinder valve block.

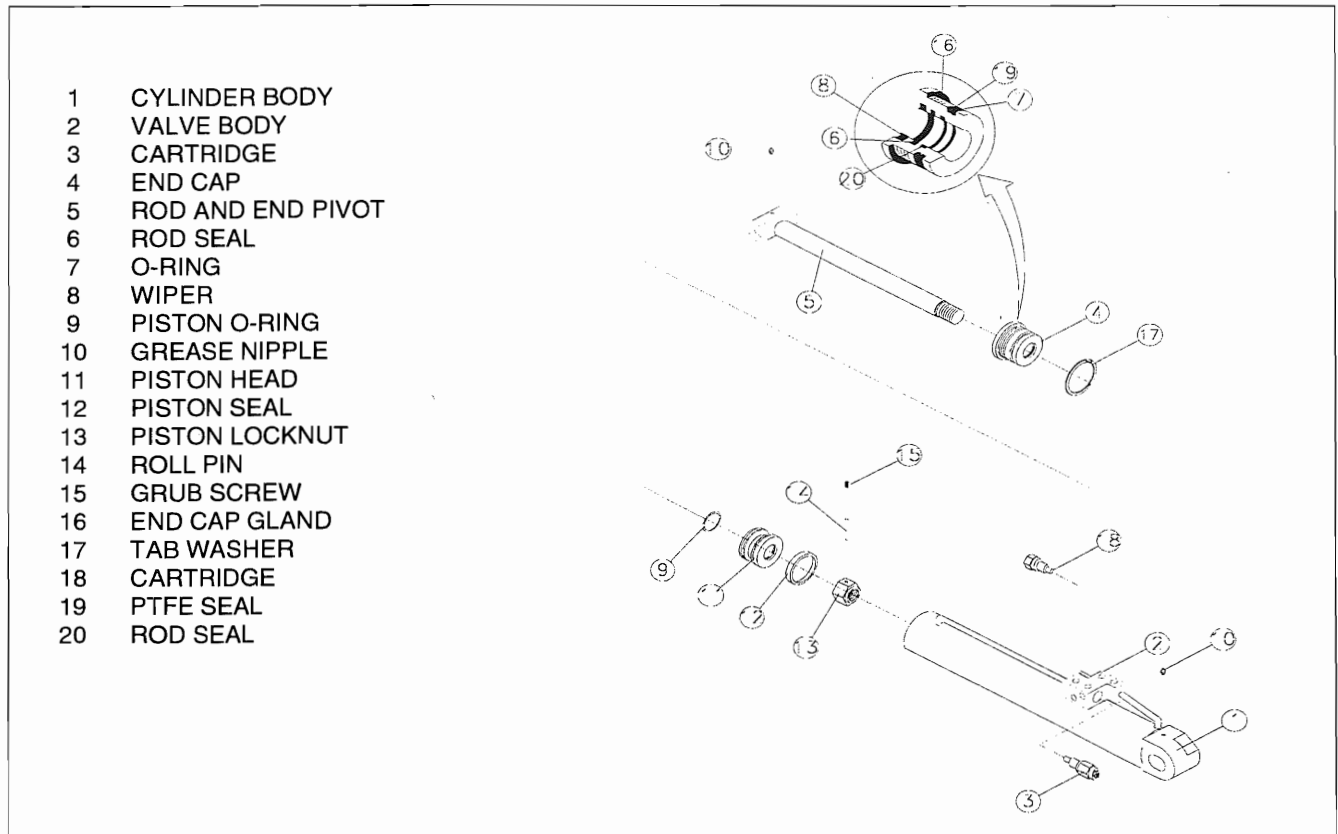

Figure 4-17: Hydraulic Cylinder Components

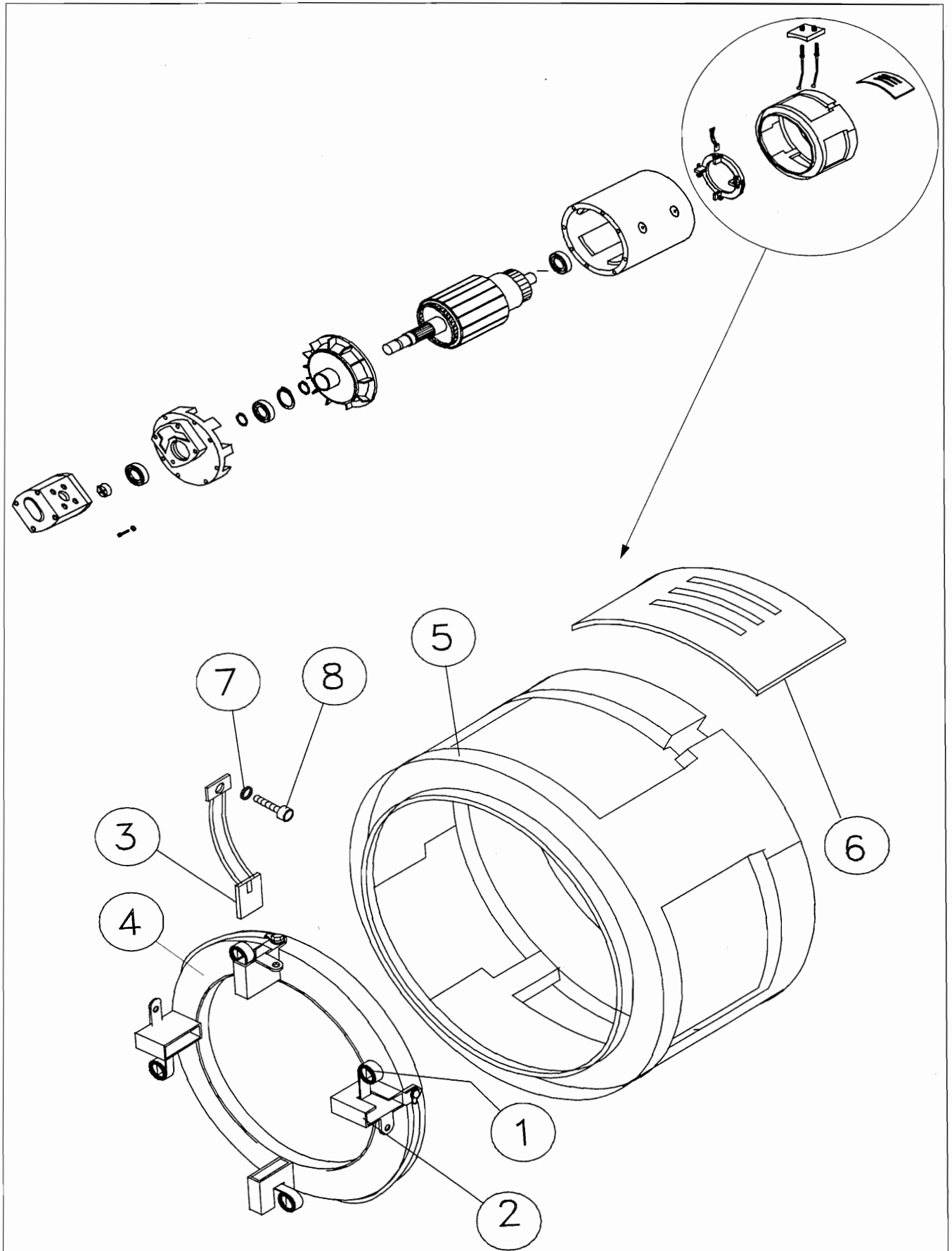



Figure 4-18: Replacement of worn motor brushes

4.11 Motor/Pump Set Maintenance

Refer to figure 4-18

 WARNING 
Before carrying out any maintenance procedures on the electric motor ensure that the electric circuit is disconnected i.e. disconnect the batteries and unplug the charger!

INSPECTING THE MOTOR PUMP SET

Remove the suction and pressure hoses from the pump and plug the hose ends to avoid excessive oil spillage. Disconnect the cables from the motor terminals noting which cables go to which terminals.

Remove the securing straps that hold the motor/pump set to the hydraulic reservoir.

Perform the maintenance inspection on a clean work surface.

Remove the inspection covers from the rear section of the motor and examine the brushes for excessive wear.

If required the brushes may need to be changed as follows:

1. Lift the spring (Item 1)
2. Remove the brushes by pulling the electric leads.
3. Release the brushes and unscrew the bolt (Item 8) from the brush box (Item 2)

NOTE: During these operations be sure that screws, washers or other materials do not fall inside the motor.

4. After thoroughly cleaning the brush holders, insert the new brushes and check that they slide correctly inside the seat (Item 2).
5. Tighten and lock the bolt (Item 8) on the seat making sure of a good electrical contact.
6. Insert the springs on the brushes between the two leads. Check the constant pressure on all the brushes, and the correct contact with the commutator.
7. Replace the inspection/ventilation covers.



Every **500** working hours

- Brushes - Check the wear, the correct seating, and the regularity of the working surface.
- Springs - They should not be burned or damaged, and they must apply a constant and equal pressure on the brushes.
- Commutator - The surface must be clean and regular without grooving or burning.

Every **1000** working hours

- Bearings- All the bearings are fitted with a double shield and lubricated with high temperature grease. Check for leaks, vibration and noise. If necessary replace with bearings of identical type.
- Seals - Check that hydraulic seals are in perfect condition.
- Screws - Check that all nuts, particularly the cable nuts and screws are tight.
- General - Check that foreign bodies or dirt have not entered the motor. Check that the ventilation holes are clean and not obstructed.

4.12 Drive Motor Maintenance

 WARNING 
Before carrying out any maintenance procedures on the drive motors ensure that the electric circuit is disconnected i.e. disconnect the batteries and unplug the charger!

INSPECTING THE DRIVE MOTORS

Refer to figure 4-19

Remove the inspection covers (item 6) from the rear section of the motor and examine the brushes for excessive wear.

If required the brushes may need to be changed as follows:

1. Lift the spring (Item 3)
 2. Release the brushes and unscrew the bolts (Item 2) from the brush box (Item 5)
 3. Remove the brushes by pulling the electric leads.
- NOTE: During these operations be sure that screws, washers or other materials do not fall inside the motor.
4. After thoroughly cleaning the brush boxes, insert the new brushes and check that they slide correctly inside the seat (Item 5).
 5. Tighten and lock the bolts (Item 2).
 6. Push the springs back in place. Check the constant pressure on all the brushes, and the correct contact with the commutator.

7. Replace the inspection/ventilation covers.

Every **500** working hours

- Brushes - Check the wear, the correct seating, and the regularity of the working surface.
- Springs - They should not be burned or damaged, and they must apply a constant and equal pressure on the brushes.
- Commutator - The surface must be clean and regular without grooving or burning.

Every **1000** working hours

- Bearings- All the bearings are fitted with a double shield and lubricated with high temperature grease. Check for leaks, vibration and noise. If necessary replace with bearings of identical type.
- Screws - Check that all nuts, particularly the cable nuts and screws are tight.
- General - Check that foreign bodies or dirt have not entered the motor. Check that the ventilation holes are clean and not obstructed.

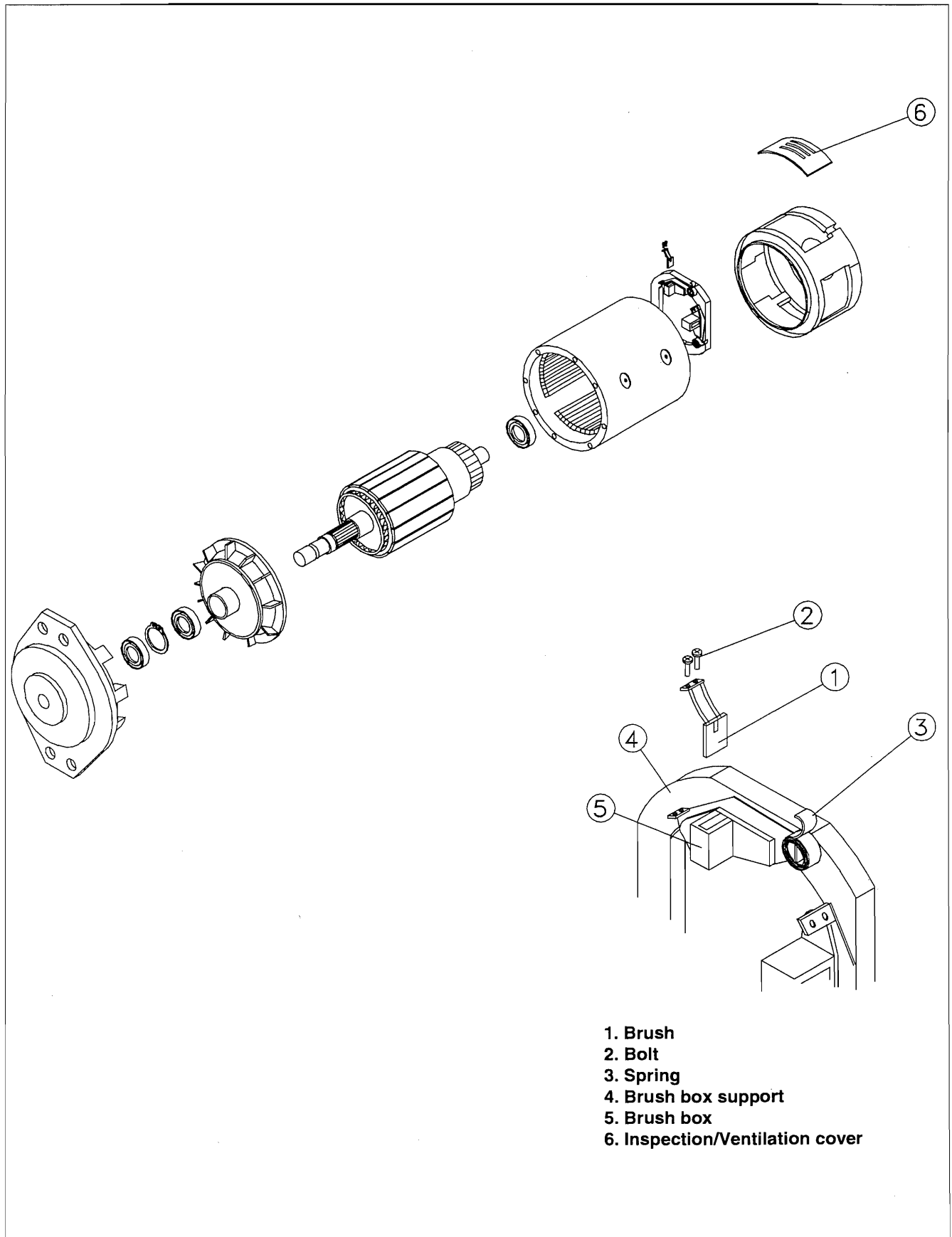

Figure 4-19: Traction motor maintenance

4.13 Drive Reduction Gearbox Maintenance

As with most gearboxes oil changes must be carried out at regular intervals.

Initially after the first 50/100 working hours and the subsequently every 2500 working hours or at least every 12 months.

For this gearbox the **minimum** recommended viscosity index is 95.

Depending on the ambient temperature of the work place the viscosity index should vary as follows:



Ambient Temperature	Viscosity Index (ISO3448)
-20°C / +5°C	VG 100
+5°C / +30°C	VG 150
+30°C / +50°C	VG 320

During oil change, we recommend that the inside of the gearcase is flushed out with flushing fluid recommended by lubricant manufacturer.

Oil should be changed when hot to prevent a build up of sludge deposit.

It is advisable to check the oil level at least once per month. If more than 10% of total oil capacity has to be added, check for oil leaks.

Do not mix oils of different types even of the same make. Never mix mineral and synthetic oils.

 **WARNING** 

Pay attention to oil and gear temperature during oil change, to avoid the risk of scalding.
Be conscious of the pollution hazard due to the oil.

CHANGING THE OIL

It is necessary to remove the gearbox in order to fully drain the oil.

- (1) The SP37 should be driven for five minutes in order to bring the oil up to working temperature.
- (2) The electric traction motor must be disconnected from the gearbox.
NOTE: Disconnect the batteries when working near the traction motors.
- (3) Unscrew the four bolts that hold the traction motor to the gearbox and pull the motor away from the rear face of the gearbox.
- (4) Disconnect the brake hose from the brake port on the gearbox and plug to avoid excessive oil spillage.

- (5) Loosen the five wheel nuts securing the wheel assembly to the gearbox studs.
- (6) Jack up the rear of the SP37 and chock the front wheels to prevent the machine from moving during the service.
- (7) Remove the wheel assembly by unscrewing the five wheel nuts
- (8) Unscrew the eight securing bolts that hold the gearbox to the chassis, and remove the gearbox noting its orientation on the chassis before removal.
- (9) Remove the oil filler and drain plugs from the front (stud) face of the gearbox.
- (10) Stand the gearbox vertically (studs facing down) in a suitable oil disposal container and allow oil to fully drain.
- (11) The gear box needs to be half filled which requires approximately 0.9 L itres of oil. To check this level, rotate the gearbox into the horizontal position with one of the filler/drain plug holes in the 3 O' Clock position and the other plug hole above it (See fig.4.20). When the gearbox is half full oil will just start to trickle out the plug hole in the 3 O'Clock position.
- (12) Insert and tighten both plugs, and clean the surfaces of the gearbox.
- (13) Re-attach the gearbox to the chassis in its original position with the eight securing bolts.
NOTE: These bolts must be torqued to 130N-m.
- (14) Re-attach the brake hose to the brake port.
- (15) Reattach the wheel assembly to the gearbox using the five M14 nuts
NOTE: These nuts must be torqued to 140N-m.
- (16) Re-attach the electric traction motor to the gearbox.
NOTE: These bolts must be torqued to 74 N-m.

Repeat this procedure for the other drive gearbox.

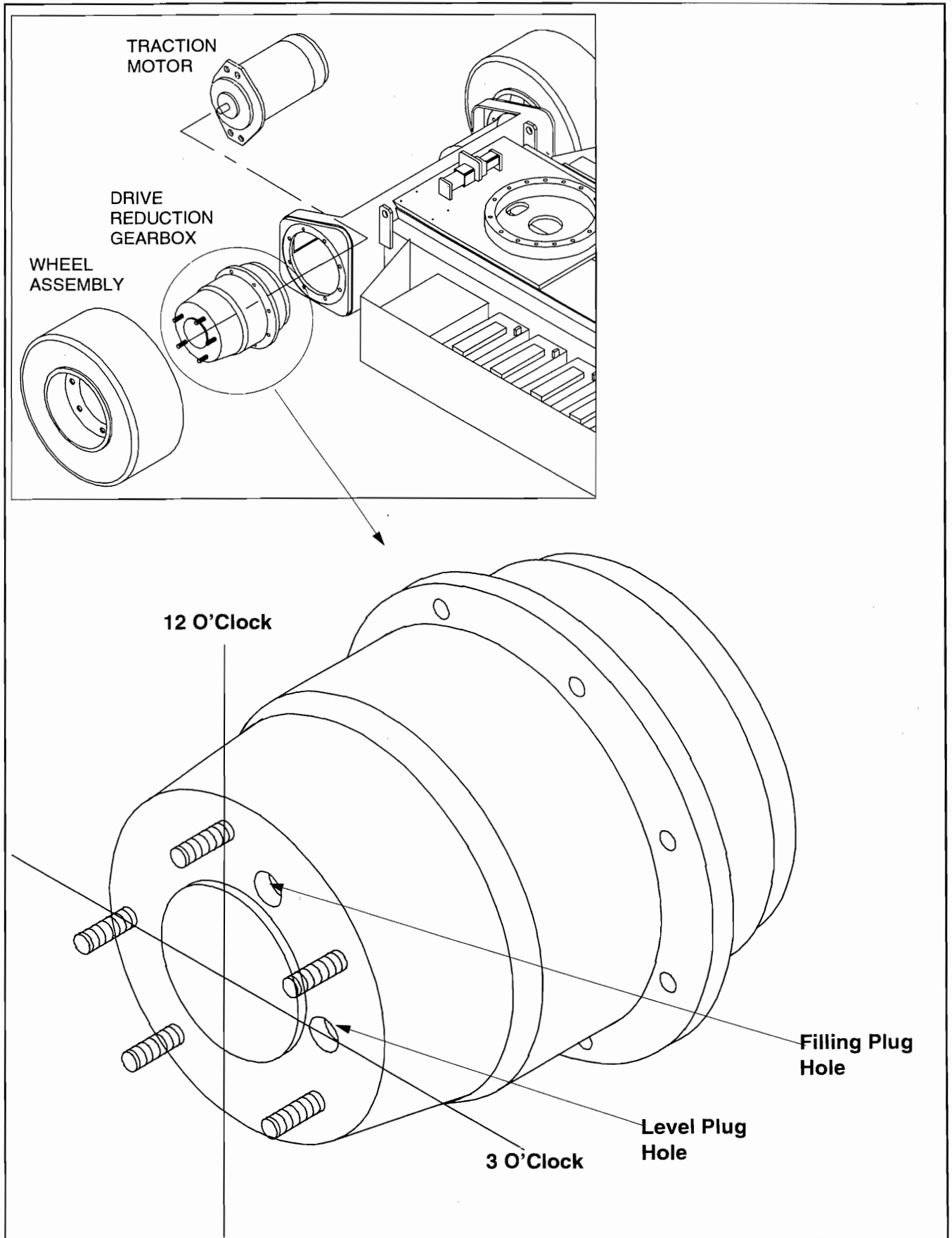

Figure 4-20: Drive reduction Gearbox

5.0 Introduction

Table 5-1 provides a logical sequence of tests that are designed to isolate problems with SP37 machines. This table includes a list of probable causes and remedies.



WARNING



When troubleshooting, ensure that the work platform is resting on a firm, level surface.

When performing any service on or in the elevating assembly area, which requires the platform to be raised, the elevating assembly

must be securely supported by overhead cranes of suitable capacity.

Disconnect the batteries ground cable when replacing or testing the continuity of any electrical component.

Trouble shooting should be carried out in two steps. First, thoroughly study both the hydraulic and electric schematics to determine possible causes. Loose terminal connections and short circuits are always a potential cause when trouble shooting. Second, check suspect components electrically, hydraulically and mechanically to determine if they are at fault. Refer to Tables 6-1 and 6-2 for References used in Table 5-1

Table 5-1: Trouble shooting

TROUBLE	PROBABLE CAUSE	REMEDY
All functions inoperable, electric motor does not start.	1. Blown electric motor fuse FU2.	Check 160 amp electric motor fuse. Replace if blown.
	2. Faulty battery charger.	Check the voltage output of the battery charger. If less than 48 VDC, repair or replace.
	3. Faulty battery(ies).	After completely charging batteries, test each battery. Replace as required.
	4. Loose or broken battery lead.	Check continuity of all battery and motor leads. Replace if necessary.
	5. Emergency Stop switch(es) (SW5, SW8) failed open.	With emergency stop switch in the ON position, check continuity across contacts. If none, replace.
	6. Blown control fuse FU3.	Check 7A circuit control fuse. Replace if blown.
	7. Plug/socket connection under Upper Control Box is not secure.	Check connection and retry.
	8. Battery Line Disconnect (BLD) plug loose in socket	Check for security of connection and retry.
All functions inoperable. Electric motor starts when control is actuated.	1. Oil level in hydraulic reservoir is low.	Check hydraulic fluid level, top off as required.
	2. Faulty hydraulic pump.	Check pressure and delivery of the hydraulic pump. Replace if required.
	3. Coupling between motor and pump damaged.	Check coupling and replace if necessary.
Electric motor continues to run after controls are returned to the neutral (OFF) position.	Line contactor (LC1) contacts fused together.	With 0 voltage at the coil terminals of the line contactor check continuity across the contact terminals. If there is continuity replace the Line Contactor.
Platform will not elevate or elevates slowly.	1. Emergency Lowering valve V12 open.	Close emergency down valve.
	2. Platform overloaded.	Observe maximum load rating. (See Table 1-1)
	3. Faulty controller at upper controls.	Check functionality of controller. Replace if faulty.

TROUBLE	PROBABLE CAUSE	REMEDY
Platform will not elevate or elevates slowly (contd...)	4. Blown control fuse FU3.	Check 7A circuit control fuse. Replace if blown.
	5. Battery level low. Check LED on motor control unit for 7 flash fault (LED will flash 7 times) due to low battery voltage.	Check Battery Voltage. Charge if necessary.
Platform will not elevate or elevates slowly.	6. Check LED on pump motor control unit for 8 flash fault (LED will flash 8 times) due to thermal cutback.	Allow unit to cool down, to clear flashing.
	7. Check LED on motor control unit for 5 flash fault (LED will flash 5 times) due to Line contactor not closing on selection of a function.	Check Line contactor for mechanical operation and coil O.K. Repair or replace if necessary.
	8. Bad connection between Lower Control Box and solenoids of lift cylinders.	Check continuity of cables and security of electrical connections. Replace or repair as necessary.
Booms drift down after being elevated	9. Solenoid coil on lift spool is faulty.	Replace with another coil to check functionality.
	1. Emergency lowering valve open.	Ensure that emergency lowering valve is completely closed. Replace the valve.
	2. Leaking piston seals in lift cylinders (CYL1, CYL2)	Check for leakage at cylinder return line, replace seals if necessary.
Platform will not lower	1. Faulty down valve coil. (SOL 9,10 pre-serial number 1023) (SOL 6,7 post serial number 1022)	Test down valve coil. If proper voltage is present and coil is not magnetised, replace.
	2. Faulty function selector switch.	Replace switch
	3. Faulty proportional controller.	Replace if necessary.
	4. Down valve (V5 or V6) stuck.	Replace relevant down valve.

Troubleshooting

TROUBLE	PROBABLE CAUSE	REMEDY
Machine will not slew when booms are elevated	<ol style="list-style-type: none"> 1. Faulty slew cut-out limit switch, LS6. 2. Coupling between slew motor and gearbox is damaged. 3. Damaged slew gearbox. 4. Oil seals in slew motor are damaged. 5. Faulty function select switch. 	<p>Check that Normally Closed contacts of limit switch are closed when second post is approximately 1m above ground. Adjust switch lever arm or Replace switch.</p> <p>Check and replace if necessary.</p> <p>Check and replace if necessary.</p> <p>Check and replace if necessary.</p> <p>Replace switch.</p>
Tele cylinder will not retract or extend.	<ol style="list-style-type: none"> 1. Shutoff ball valve SBV is open. 2. Platform is overloaded 	<p>Close Shutoff ball valve.</p> <p>Reduce load.</p>
Cage levelling is erratic or not regular throughout lift cycle.	<ol style="list-style-type: none"> 1. Air in cage levelling closed circuit. 2. Damaged overcentre cartridges in levelling cylinders. 3. Cradle damaged and hole centres are out of position. 	<p>Bleed oil from levelling circuit. Reprime and level cage on boomrest through full cycle several times.</p> <p>Remove and inspect O-Rings and seals. Replace if Necessary.</p> <p>Replace.</p>
Machine will not drive.	<ol style="list-style-type: none"> 1. Check LED on traction motor control unit for 8 flash fault (LED will flash 8 times) due to thermal cutback. 2. 8m drive cut-out switch activated. 3. Fuses FU1 and/or FU3 blown. 4. Check LED on traction motor control unit for 11 flash fault (LED will flash 11 times due to tachometer being disconnected or leads on the wrong way. 	<p>Allow unit to cool down, to clear flashing.</p> <p>Lower cage below 8m and retry.</p> <p>Check fuses and replace if necessary</p> <p>Check tachometer leads for secure connection or reverse the leads.</p>

TROUBLE	PROBABLE CAUSE	REMEDY
Machine will not drive (Contd...)	<ol style="list-style-type: none"> 5. Check LED on traction motor control unit for 4 flash fault (LED will flash 4 times) due to direction contactor welded. 6. Loose electrical connection on drive motor or motor control units. 7. Brakes engaged. Brake solenoid V2 (marked CT12) has become de-energised or the spool is stuck in the open position. 8. Brakes engaged. Brake solenoid V1 (marked CT11) is not energising to prime the brake lines. 9. Drive Reduction Gearbox has seized due to lack of oil. 10. Joystick controller damaged or faulty 	<p>Check direction contactor tips and free or replace if welded.</p> <p>Check all electrical connections relating to the drive system for security.</p> <p>Check that coil of V2 is energised when drive is selected. Remove cartridge and check for contamination and freedom of movement of spool. Replace if necessary.</p> <p>Check that the coil of V1 energises for approximately 4 seconds by a delay module when drive is selected. If no current is being fed to this coil then replace cable feeding the coil or replace the P.C.B. in the lower control box. NOTE: Units pre-serial 1023 have the delay module mounted externally on the motor control unit.</p> <p>Replace gearbox and ensure proper oil level is maintained.</p> <p>Check for voltage signal on pin 8 or 11 on the traction motor control unit when forward or reverse is selected using the joystick.</p>
Machine will not steer	<ol style="list-style-type: none"> 1. Faulty rocker switch on joystick controller handle. 2. Loose connection on steer solenoid valve V8. 3. Faulty Steering Valve Coil. 	<p>Replace if necessary</p> <p>Re-connect if necessary.</p> <p>Test Steering valve coil. If proper voltage is present and coil is not magnetised, replace.</p>

Table 5-1: Trouble shooting

TROUBLE	PROBABLE CAUSE	REMEDY
Machine will not steer (contd...)	4. Steering valve V8 stuck.	Replace valve.
	5. Mechanical Damage.	Replace damaged parts.
Machine drives forward but not in reverse	1. Faulty drive switch	Test and replace if necessary.
	2. Loose connection or continuity lost to reverse contactor coil.	Check continuity and cable connections. Repair or replace as necessary.
	3. Reverse contactor coil faulty.	Check that coil is receiving 48v. If it is and contacts are not closing then replace contactor.
Machine drives in reverse but not forwards	1. Faulty drive switch	Test and replace if necessary.
	2. Loose connection or continuity lost to forward contactor coil.	Check continuity and cable connections. Repair or replace as necessary.
	3. Forward contactor coil faulty.	Check that coil is receiving 48v. If it is and contacts are not closing then replace contactor.
Machine will not drive at full speed when booms are stowed	1. Faulty boom rest switch.	Test and replace switch if necessary.
	2. Loss of continuity along boomrest switch cable.	Check continuity and repair if necessary

A large, empty rectangular box with a thin black border, occupying the majority of the page. It is intended for the user to write notes related to the section.

6.0 Introduction

This section contains electrical and hydraulic power schematics and associated information for maintenance purposes.

The diagrams are to be used in conjunction with Table 5-1: Troubleshooting Guide. They allow understanding of the makeup and functions of the systems for checking, tracing, and faultfinding during troubleshooting analysis.

The components that comprise the electrical and hydraulic systems are given a reference designation and are explained as to function and location in the following tables.

INDEX

Figure	Page
6-1: Electrical Schematic	6.5
6-2: Hydraulic Schematic	6.7
6-3: Hydraulic Manifolds	6.7

This Page Intentionally Left Blank

Schematics

6.1 Electrical Schematic SERIAL NUMBERS 1001 TO 1022

Table 6-1: Electrical Schematic Legend

REFERENCE DESIGNATION	NAME	FUNCTION	LOCATION
ALM1	Alarm, Tilt	Provides warning sound when tilt unit (TAL) is activated (tilted).	In Upper Control Box
ALM2	Movement Alarm	When the machine is driving this alarm has an intermittent sound.	On Motor Control Unit.
BAT	Batteries (8) 6Volts each.	To store energy (48V system)	Battery compartments on chassis
D1	Diode	Sends a signal to Pin 11 on the pump controller when level up function is selected and prevents backfeed to the level up solenoid when level down is selected	On lower control box P.C.B.
D2	Diode	Sends a signal to Pin 11 on the pump controller when level down function is selected and prevents backfeed to the level down solenoid when level up is selected	On lower control box P.C.B.
D3	Diode	Feeds power to tele-out solenoid from upper controls and prevents feed-back to upper controls from lower controls.	On lower control box P.C.B.
D4	Diode	Feeds power to tele-out solenoid from lower controls and prevents feed-back to lower controls from upper controls.	On lower control box P.C.B.
D5	Diode	Feeds a signal from tele cylinder (out) solenoid to pin 4 on the pump controller and prevents backfeed to the tele-out solenoid when other functions are selected.	On lower control box P.C.B.
D6	Diode	Feeds power to tele-in solenoid from upper controls and prevents feed-back to lower controls from upper controls.	On lower control box P.C.B.
D7	Diode	Feeds power to tele-in solenoid from lower controls and prevents feed-back to lower controls from upper controls.	On lower control box P.C.B.
D8	Diode	Feeds a signal from tele cylinder (in) solenoid to pin 4 on the pump controller and prevents backfeed to the tele-in solenoid when other functions are selected.	On lower control box P.C.B.
D9	Diode	Feeds a signal from lower lift cylinder (up) solenoid to pin 4 on the pump controller and prevents backfeed to the solenoid when other functions are selected.	On lower control box P.C.B.
D10	Diode	Feeds a signal from upper lift cylinder (up) solenoid to pin 4 on the pump controller and prevents backfeed to the lift solenoid when other functions are selected.	On lower control box P.C.B.
D11	Diode	Feeds a signal from lower lift cylinder (down) solenoid to pin 4 on the pump controller and prevents backfeed to the lower lift solenoid when other functions are selected.	On lower control box P.C.B.
D12	Diode	Feeds a signal from upper lift cylinder (down) solenoid to pin 4 on the controller and prevents backfeed to the upper lift solenoid when other functions are selected.	On lower control box P.C.B.
D13	Diode	Feeds power to slew right solenoid from upper controls and prevents feed-back to upper controls from lower controls.	On lower control box P.C.B.
D14	Diode	Feeds power to slew right solenoid from lower controls and prevents feed-back to lower controls from upper controls.	On lower control box P.C.B.

REFERENCE	NAME	FUNCTION	LOCATION
D15	Diode	Feeds power to lower cylinder (up) solenoid from upper controls and prevents feed-back to upper controls from lower controls.	On lower control box P.C.B.
D16	Diode	Feeds power to lower cylinder (up) solenoid from lower controls and prevents feed-back to lower controls from upper controls.	On lower control box P.C.B.
D17	Diode	Feeds power to upper cylinder (up) solenoid from upper controls and prevents feed-back to upper controls from lower controls.	On lower control box P.C.B.
D18	Diode	Feeds power to upper cylinder (up) solenoid from lower controls and prevents feed-back to lower controls from upper controls.	On lower control box P.C.B.
D19	Diode	Feeds power to slew left solenoid from upper controls and prevents feed-back to upper controls from the lower controls.	On lower control box P.C.B.
D20	Diode	Feeds power to slew left solenoid from lower controls and prevents feed-back to lower controls from upper controls.	On lower control box P.C.B.
D21	Diode	Feeds power to lower cylinder (down) solenoid from upper controls and prevents feed-back to upper controls from lower controls.	On lower control box P.C.B.
D22	Diode	Feeds power to lower cylinder (down) solenoid from lower controls and prevents feed-back to lower controls from upper controls.	On lower control box P.C.B.
D23	Diode	Feeds power to upper cylinder (down) solenoid from upper controls and prevents feed-back to upper controls from lower controls.	On lower control box P.C.B.
D24	Diode	Feeds power to upper cylinder (down) solenoid from lower controls and prevents feed-back to lower controls from upper controls.	On lower control box P.C.B.
D25	Diode	Feeds +24V to pin 6 on the controller from lower controls.	On lower control box P.C.B.
D26	Diode	Feeds +24V to pin 6 on the controller when keyswitch is switched to upper controls	On lower control box P.C.B.
D27	Diode	Feeds a power signal to the movement alarm when forward drive is selected	On lower control box P.C.B.
D28	Diode	Feed a power signal to the movement alarm when reverse drive is selected	On lower control box P.C.B.
D29	Diode	Feeds power signal from joystick at upper controls to line contactor when trigger is pulled.	On lower control box P.C.B.
D30, D31	Diode	Feed a signal to pin 7 on the controller when slew is energised by lower controls. They prevent backfeed to the slew solenoids when upper slew signal (in tilt situation) is fed to pin 7.	On lower control box P.C.B.
D32	Diode	Feeds a power signal to line contactor when keyswitch is turned to lower controls.	On lower control box P.C.B.
D33	Diode	Prevents backfeed from boom solenoids to interface module when K2 is energised	On lower control box P.C.B.
D34	Diode	Feeds power to the titl alarm when the keyswitch is turned to lower controls . It prevents backfeed to lower controls from upper control signal (D35)	On lower control box P.C.B.
D35	Diode	Feeds power to the titl alarm when the keyswitch is turned to upper controls. It prevents backfeed to upper controls from loeer control signal (D34)	On lower control box P.C.B.
D36 - D49	Diode	Suppression diodes for solenoid coils 1-14 .	On lower control box P.C.B.
D50, D51	Diode	Suppression diode for the coils of directional control relays (RL1 & R2)	Upper Control Box P.C.B.
D52	Diode	?	
D53	Diode	Feeds a signal to Pin 12 on the controller when tele-out function is selected at the upper controls and prevents back feed to tele-in solenoid.	Upper Control Box
D54	Diode	Feeds a signal to Pin 12 on the controller when tele-in function is selected at the upper controls and prevents back feed to tele-out solenoid.	Upper Control Box

REFERENCE	NAME	FUNCTION	LOCATION
D55	Diode	Feeds power to Emergency stop contact at upper controls and prevents backfeed to normal upper controls when emergency override is selected.	UCB
D56, D59	Diode	Feeds a signal to pin 13 on the controller via the slew cut-out limit switch (LS1) when the slew function is selected at the upper controls	UCB
D57, D60	Diode	Feeds a signal to pin 8 on the controller when the lower cylinder lift function is selected at the upper controls. It prevents backfeed to the lower lift solenoid when the upper lift cylinder solenoid is energised.	UCB
D58, D61	Diode	Feeds a signal to pin 8 on the controller when the upper cylinder lift function is selected at the upper controls. It prevents backfeed to the upper lift solenoid when the lower lift cylinder solenoid is energised.	UCB
D62	Diode	Feeds power to upper control components when emergency override is used.	UCB
D63	Diode	Supression diode for line contactor.	On line contactor
D64	Diode	Feeds a signal to the delay module when forward drive is selected and prevents backfeed to reverse contactor.	On controller
D65	Diode	Feeds a signal to the delay module when reverse drive is selected and prevents backfeed to forward contactor.	On controller
D66, D67	Diode	Feeds a signal to Pin 16 on the pump controller when the steer function is selected	Lower Control Box
DC1	Direction contactor	Provides the means to reverse the direction of current through the traction motor field windings and thus reverses the direction of the electromagnetic field.	On M.C.U
DM	Delay Module	On selection of traction drive and foward/reverse the brake solenoids Sol13 & Sol14 together with the lift pump contactor are energised .This diverts oil to the brake chamber and releases the brakes. This operation is required for approx. 4 seconds. When the brake lines are primed after this period the oil pressure is maintained by keeping Sol14 energised and Sol13 and the lift pump contactor can be de-energised. The Delay Module circuitry achieves this.	On M.C.U
FU1	Fuse 425 Amps	Overload protection for drive electric motors	On MCU
FU2	Fuse 325 Amps	Overload protection for pump electric motor	On MCU
KSW1	Keyswitch 3-Position	Diverts power to upper or lower control boxes	Outrigger control box
LS1	Limit switch slew cut-out & Boom raised travel speed	Prevents slewing until 2nd post is clear of the wheels. The slew signal to pin 13 on the pump controller is broken through the open (normally closed) contacts until 2nd post is clear of wheels. Sends a signal to pin 4 on the traction controller when the booms are on LS1 and the Normally open contact closes. * Cage levelling is available only when booms are stowed and second normally open contact is closed. (CE Mark units only)	On First Post
LS2 * CE Mark units only	8M cut-out	Disables drive when booms are elevated above 8M. It cuts the signal to pin 7 on the traction MCU	On second post

Schematics

6.1 Electrical Schematic SERIAL NUMBERS 1023 TO CURRENT
Table 6-1: Electrical Schematic Legend

REFERENCE	NAME	FUNCTION	LOCATION
ALM1	Alarm, Tilt	Provides warning sound when tilt unit (TAL) is activated (tilted).	In Upper Control Box
ALM2	Movement Alarm	When the machine is driving this alarm has an intermittent sound.	On Motor Control Unit.
BAT	Batteries (8) 6Volts each.	To store energy (48V system)	Battery compartments on chassis
D1-D14	Diode	Suppression diodes for solenoid coils 1-14	On lower control box P.C.B.
D15	Diode	Sends a signal to Pin 11 on the pump controller when level up function is selected and prevents backfeed to the level up solenoid when level down is selected	On lower control box P.C.B.
D16	Diode	Sends a signal to Pin 11 on the pump controller when level down function is selected and prevents backfeed to the level down solenoid when level up is selected	On lower control box P.C.B.
D17	Diode	Feeds a signal from lower lift cylinder (up) solenoid to pin 4 on the pump controller and prevents backfeed to the solenoid when other functions are selected.	On lower control box P.C.B.
D18	Diode	Feeds a signal from upper lift cylinder (up) solenoid to pin 4 on the pump controller and prevents backfeed to the lift solenoid when other functions are selected.	On lower control box P.C.B.
D19	Diode	Feeds a signal from tele cylinder (out) solenoid to pin 4 on the pump controller and prevents backfeed to the tele-out solenoid when other functions are selected.	On lower control box P.C.B.
D20	Diode	Feeds a signal from lower lift cylinder (down) solenoid to pin 4 on the pump controller and prevents backfeed to the lower lift solenoid when other functions are selected.	On lower control box P.C.B.
D21	Diode	Feeds a signal from upper lift cylinder (down) solenoid to pin 4 on the controller and prevents backfeed to the upper lift solenoid when other functions are selected.	On lower control box P.C.B.
D22	Diode	Feeds power to lower cylinder (up) solenoid from upper controls and prevents feed-back to upper controls from lower controls.	On lower control box P.C.B.
D23	Diode	Feeds power to lower cylinder (up) solenoid from lower controls and prevents feed-back to lower controls from upper controls.	On lower control box P.C.B.
D24	Diode	Feeds power to upper cylinder (up) solenoid from upper controls and prevents feed-back to upper controls from lower controls.	On lower control box P.C.B.
D25	Diode	Feeds power to upper cylinder (up) solenoid from lower controls and prevents feed-back to lower controls from upper controls.	On lower control box P.C.B.
D26	Diode	Feeds power to upper cylinder (down) solenoid from lower controls and prevents feed-back to lower controls from upper controls.	On lower control box P.C.B.
D27	Diode	Feeds power to upper cylinder (down) solenoid from upper controls and prevents feed-back to upper controls from lower controls.	On lower control box P.C.B.

REFERENCE	NAME	FUNCTION	LOCATION
D28	Diode	Feeds power to tele-out solenoid from upper controls and prevents feed-back to upper controls from lower controls.	On lower control box P.C.B.
D29	Diode	Feeds power to tele-out solenoid from lower controls and prevents feed-back to lower controls from upper controls.	On lower control box P.C.B.
D30	Diode	Feeds power to lower cylinder (down) solenoid from upper controls and prevents feed-back to upper controls from lower controls.	On lower control box P.C.B.
D31	Diode	Feeds power to lower cylinder (down) solenoid from lower controls and prevents feed-back to lower controls from upper controls.	On lower control box P.C.B.
D32	Diode	Feeds a signal from tele cylinder (in) solenoid to pin 4 on the pump controller and prevents backfeed to the tele-in solenoid when other functions are selected.	On lower control box P.C.B.
D33	Diode	Feeds power to tele-in solenoid from upper controls and prevents feed-back to lower controls from upper controls.	On lower control box P.C.B.
D34	Diode	Feeds power to tele-in solenoid from lower controls and prevents feed-back to lower controls from upper controls.	On lower control box P.C.B.
D35, D36	Diode	Feeds a signal to Pin 16 on the pump controller when the steer function is selected	Lower Control Box
D37	Diode	Feeds a power signal to the movement alarm when forward drive is selected	On lower control box P.C.B.
D38	Diode	Feed a power signal to the movement alarm when reverse drive is selected	On lower control box P.C.B.
D39	Diode	Feeds power to slew right solenoid from upper controls and prevents feed-back to upper controls from lower controls.	On lower control box P.C.B.
D40	Diode	Feeds power to slew right solenoid from lower controls and prevents feed-back to lower controls from upper controls.	On lower control box P.C.B.
D41	Diode	Feeds power to slew left solenoid from upper controls and prevents feed-back to upper controls from the lower controls.	On lower control box P.C.B.
D42	Diode	Feeds power to slew left solenoid from lower controls and prevents feed-back to lower controls from upper controls.	On lower control box P.C.B.
D43, D44	Diode	Feed a signal to pin 7 on the controller when slew is energised by lower controls. They prevent backfeed to the slew solenoids when upper slew signal (in tilt situation) is fed to pin 7.	On lower control box P.C.B.
D45	Diode	Feeds +48V to pin 6 on the controller from lower controls.	On lower control box P.C.B.
D46	Diode	Feeds +48V to pin 6 on the controller when keyswitch is switched to upper controls	On lower control box P.C.B.
D47	Diode	Feeds power to the tilt alarm when the keyswitch is turned to upper controls. It prevents backfeed to upper controls from lower control signal (D51)	On lower control box P.C.B.
D48	Diode	Feeds power signal from joystick at upper controls to line contactor when trigger is pulled.	On lower control box P.C.B.
D50	Diode	Prevents backfeed from boom solenoids to upper control box when K2 is energised	On lower control box P.C.B.
D51	Diode	Feeds power to the tilt alarm when the keyswitch is turned to lower controls. It prevents backfeed to lower controls from upper control signal (D47)	On lower control box P.C.B.
D52	Diode	Feeds a power signal to line contactor when keyswitch is turned to lower controls.	On lower control box P.C.B.
D57	Diode	Prevents backfeed from suppression/tacho circuitry to upper control line	On lower control box P.C.B.
D63	Diode	Suppression diode for line contactor.	On line contactor
D64	Diode	Prevents backfeed to forward contactor when Sol 14 is activated by reverse contactor	On lower P.C.B.
D65	Diode	Prevents backfeed to reverse contactor when Sol 14 is activated by forward contactor	On lower P.C.B.

REFERENCE	NAME	FUNCTION	LOCATION
D66	Diode	Backfeed protection for suppression circuitry	LCB
D67, D68	Diode	Feeds a signal to pin 13 on the controller via the slew cut-out limit switch (LS2) when the slew function is selected at the upper controls	UCB
D69	Diode	Feeds a signal to Pin 12 on the controller when tele-in function is selected at the upper controls and prevents back feed to tele-out solenoid.	Upper Control Box
D70	Diode	Feeds a signal to Pin 12 on the pump controller when tele-out function is selected at the upper controls and prevents back feed to tele-in solenoid.	Upper Control Box
D71	Diode	Suppression diode for coil of relay K3	LCB
D72	Diode	Suppression diode for coil of relay K1	LCB
D1, D2	Diode	Suppression diode for the coils of directional control relays (RL1 & R2)	Upper Control Box P.C.B.
D3, D5	Diode	Feeds a signal to pin 8 on the controller when the lower cylinder lift function is selected at the upper controls. It prevents backfeed to the lower lift solenoid when the upper lift cylinder solenoid is energised.	UCB
D4, D6	Diode	Feeds a signal to pin 8 on the controller when the upper cylinder lift function is selected at the upper controls. It prevents backfeed to the upper lift solenoid when the lower lift cylinder solenoid is energised.	UCB
D7	Diode	Prevents backfeed to normal upper controls when emergency override is selected.	UCB
D8	Diode	Prevents backfeed to emergency control contacts when normal uppercontrol functions are in use.	UCB
D9	Diode	Prevents backfeed to emergency functions from normal functions in tilt situation.	UCB
D10	Diode	Prevents backfeed to normal upper controls through the level switch in a tilt situation	UCB
DC1	Direction contactor	Provides the means to reverse the direction of current through the traction motor field windings and thus reverses the direction of the electromagnetic field.	On M.C.U
DM	Delay Module	On selection of traction drive and forward/reverse the brake solenoids Sol13 & Sol14 together with the lift pump contactor are energised. This diverts oil to the brake chamber and releases the brakes. This operation is required for approx. 4 seconds. When the brake lines are primed after this period the oil pressure is maintained by keeping Sol14 energised and Sol13 and the lift pump contactor can be de-energised. The Delay Module circuitry achieves this.	On M.C.U
FU1	Fuse 425 Amps	Overload protection for drive electric motors	On MCU
FU2	Fuse 325 Amps	Overload protection for pump electric motor	On MCU
FU3	Fuse 7 Amps	Overload protection for control circuitry	On MCU
KSW1	Keyswitch 3-Position	Diverts power to upper or lower control boxes	Lower control box
LS1	Boom raised travel speed	Sends a signal to pin 4 on the traction controller when the booms are stowed on LS1 and the Normally open contact closes. * Cage levelling is available only when booms are stowed and second normally open contact is closed. (CE Mark units only)	On First Post
LS2	Slew cut-out limit switch	Prevents slewing until 2nd post is clear of the wheels. The slew signal to pin 13 on the pump controller is broken through the open (normally closed) contacts until 2nd post is clear of wheels.	On first post

6.1 Electrical Schematic **SERIAL NUMBERS 1001 TO 1022**

Table 6-1: Electrical Schematic Legend (Contd...)

REFERENCE	NAME	FUNCTION	LOCATION
K1	Relay	Timed relay to switch in the pump controller during timed section (4 seconds approx.)	In Lower Control Box
K2	Tilt Relay	(Constantly energised when the machine is level) This allows the tilt unit (TAL) to switch over circuits on P.C.B. to restrict the non tilt operations. It feeds a constant signal to pin 7 on the traction controller when the machine is level.	In Lower Control Box
K3	Tilt/Override relay	Energised when machine is tilted more than 3°. It breaks the upper control tele speed signal and changes upper slew speed to lower slew speed.	In Lower Control Box
K4	Tilt/Override relay	Energised when machine is tilted more than 3°. It disables cage levelling and sends power to the pump contact of SW11.	In Upper Control Box
K5	Joystick direction relay	This relay is energised when the joystick is pushed forward. The contacts close allowing +48V to be fed into only one half of the contacts on the selector switch. This then allows only one of the two solenoids on each function spool to be energised thus allowing only one direction of motion when the joystick is pushed forward.	UCB
K6	Joystick direction relay	This relay is energised when the joystick is pulled backwards. The contacts close and feed +48V to the opposite set of contacts in the selector switch as K5 does. This then energises the opposite solenoid for each function and provides motion in the opposite direction when the joystick is pulled back.	UCB
LC1	Line Contactor	In the unenergised state the Normally Closed contacts allow the charger +V feed to the batteries. In the energised state the Normally Open contacts close and route the battery current to the motor	On motor control unit on the chassis equipment subframe
LED1	Battery Indicator	The LED remains off when the batteries are fully charged. The LED flashes when the batteries begin to discharge. The LED will remain on when the batteries are fully discharged.	Upper Control Panel
LED2	Outrigger Light Emitting Diode	This LED is illuminated when there is power at the upper controls	Upper Control Panel
MCU1	Traction Motor Control Unit	Controls the speed of the electric traction motors. Using upper control joystick the motor speed varies with the position of the control joystick. The change in speed of the motors is caused by the varying output of current from the M.C.U. into the motors armature and field.	On chassis equipment subframe

REFERENCE	NAME	FUNCTION	LOCATION
MCU2	Pump Motor Control Unit	Controls the speed of the pump electric motor. Using upper controls the motor speed varies with the position of the control joystick. Using the lower controls the motor has different fixed speeds for the various functions which are programmed into the MCU using a special calibrator.	On chassis equipment subframe
MOT	48V D.C. Electric Motor	This motor is close coupled to the hydraulic pump which provides the oil flow and pressure to operate the various machine functions.	On chassis equipment subframe.
SW1	Function switch Lower Boom	Sends power to lower lift cylinder control solenoid which diverts oil to full bore or annular side of lower lift cylinder. It also sends a signal via diodes D11 and D9 to the controller which activate the motor & pump.	LCB
SW2	Function switch Upper Boom	Sends power to lower lift cylinder control solenoid which diverts oil to full bore or annular side of upper lift cylinder. It also sends a signal via diodes D12 and D10 to the controller which activate the motor & pump	LCB
SW3	Function switch Tele Boom	Sends power to tele cylinder control solenoid which diverts oil to full bore or annular side of tele lift cylinder. It also sends a signal via diodes D5 and D8 to the controller which activate the motor & pump	LCB
SW4	Function switch slew motor	Sends power to slew motor control solenoid which diverts oil to the left or right side of the slew motor. It also sends a signal via diodes D30 and D31 to the controller which activate the motor & pump	LCB
SW5	Emergency stop button	Control circuit shut off.	LCB
SW6	Function switch Levelling	Sends power to Levelling control solenoid which diverts oil to the annular or full bore side of the slave levelling cylinder. It also sends a signal via diodes D1 and D2 to the controller.	UCB
SW7	Switch - 4-Position selector	Sends power to selected solenoid valve (lower lift, upper lift, tele & slew). Only one function can be selected at one time.	UCB
SW8	Emergency stop button	Control circuit shut off.	UCB
SW9	Switch, Emergency Override	Provides emergency power when power is cut to the upper controls due to a tilt situation.	UCB
SW10	Switch, On/Off	Allows +48V supply to feed upper controls. Allows signals from tele and lift functions to pass down to the controller. Allows Joystick trigger signal to pass down to the controller	UCB
SW11	Drive/lift switch	Switches to either drive or boom lift function	UCB
SW12	Horn switch	Activates horn in chassis	UCB
TAL	Tilt switch	This tilt alarm when level gives a constant supply back through the white cable and energises the tilt relay K1. When the machine is tilted supply is removed from the white cable.	Chassis

PUMP MOTOR CONTROL UNIT PIN LEGEND

PIN No.	DESCRIPTION
1	Battery Discharge Indicator (B.D.I.) output
2	Not used - sw8 - Switch 8
3	Not used - 10v Supply
4	sw4 - Switch 4 (Speed 4: Boom speeds from lower controls - Factory set at 40%)
5	Not used - Not connected
6	48V supply (Must be greater than 14 Volts)
7	sw5 - (Speed 5: Lower control slew speed - Factory set at 17%)
8	sw1 - Switch 1 (Speed 1: Max. Variable speed for Upper and Lower lift cylinders from upper controls - Factory set at 75 %)
9	Not used - Accel. supply
10	Not used - Not connected
11	sw7 - Switch 7 (Speed 7: Levelling speed from upper controls - Factory set at 20%)
12	sw3 - Switch 3 (Speed 3: Max. Variable speed for Tele cylinder from upper controls - Factory set at 100%)
13	sw2 - Switch 2 (Speed 2 : Max. Variable slewing speed from upper controls - Factory set at 38%)
14	Accelerator (3.5v-0v) - Input from joystick to vary motor speed from upper controls.
15	Not used - Not connected
16	sw6 - Switch 6 (Speed 6: Steer speed - Factory set at 40%)
17	Not used - Not connected

TRACTION MOTOR CONTROL UNIT PIN LEGEND

PIN No.	DESCRIPTION
1	Not used - Not connected
2	sw7 - Direction signal from tacho generator.
3	Not used - Not connected
4	sw4 - Boom elevated signal
5	+48V supply
6	+48V supply
7	sw5 - Off level signal
8	sw1 - Forward direction signal from upper controls
9	Not used - Not connected
10	Not used - Not connected
11	sw2 - Reverse direction signal from upper controls
12	sw3 - Speed signal from Tacho circuitry
13	Not used - Not connected
14	Accelerator (3.5v-0v) - Input from joystick to vary motor speed from upper controls.
15	Signal to forward contactor
16	Not used - Not connected
17	Signal to reverse contactor

6.1 Electrical Schematic SERIAL NUMBERS 1023 TO CURRENT
Table 6-1: Electrical Schematic Legend (Contd...)

REFERENCE	NAME	FUNCTION	LOCATION
LS3 * CE Mark units only	8M cut-out	Disables drive when booms are elevated above 8M. It cuts the signal to pin 7 on the traction MCU	On second post
K1	Tilt Relay	(Constantly energised when the machine is level)This allows the tilt unit (TAL) to switch over circuits on P.C.B. to restrict the non tilt operations. It feeds a constant signal to pin 7 on the traction controller when the machine is level.	In Lower Control Box
K2	Relay	Timed relay to switch in the pump controller during timed section (4 seconds approx.)	In Lower Control Box
K3	Tilt/Override relay	Energised when machine is tilted more than 3°. It breaks the upper control tele speed signal and changes upper slew speed to lower slew speed.	In Lower Control Box
K4	Tilt/Override relay	Energised when machine is tilted more than 3°. It disables cage levelling and sends power to the pump contact of SW11.	In Upper Control Box
K5	Joystick direction relay	This relay is energised when the joystick is pushed forward. The contacts close allowing +48V to be fed into only one half of the contacts on the selector switch. This then allows only one of the two solenoids on each function spool to be energised thus allowing only one direction of motion when the joystick is pushed forward.	UCB
K6	Joystick direction relay	This relay is energised when the joystick is pulled backwards. The contacts close and feed +48V to the opposite set of contacts in the selector switch as K5 does. This then energises the opposite solenoid for each function and provides motion in the opposite direction when the joystick is pulled back.	UCB
LC1	Line Contactor	In the unenergised state the Normally Closed contacts allow the charger +V feed to the batteries. In the energised state the Normally Open contacts close and route the battery current to the motor	On motor control unit on the chassis equipment subframe
LED1	Battery Indicator	The LED remains off when the batteries are fully charged. The LED flashes when the batteries begin to discharge. The LED will remain on when the batteries are fully discharged.	Upper Control Panel
LED2	Outrigger Light Emitting Diode	This LED is illuminated when there is power at the upper controls	Upper Control Panel
MCU1	Traction Motor Control Unit	Controls the speed of the electric traction motors. Using upper control joystick the motor speed varies with the position of the control joystick. The change in speed of the motors is caused by the varying output of current from the M.C.U. into the motors armature and field.	On chassis equipment subframe

REFERENCE	NAME	FUNCTION	LOCATION
MCU2	Pump Motor Control Unit	Controls the speed of the pump electric motor. Using upper controls the motor speed varies with the position of the control joystick. Using the lower controls the motor has different fixed speeds for the various functions which are programmed into the MCU using a special calibrator.	On chassis equipment subframe
MOT	48V D.C. Electric Motor	This motor is close coupled to the hydraulic pump which provides the oil flow and pressure to operate the various machine functions.	On chassis equipment subframe.
SW1	Function switch Lower Boom	Sends power to lower lift cylinder control solenoid which diverts oil to full bore or annular side of lower lift cylinder.	LCB
SW2	Function switch Upper Boom	Sends power to lower lift cylinder control solenoid which diverts oil to full bore or annular side of upper lift cylinder.	LCB
SW3	Function switch Tele Boom	Sends power to tele cylinder control solenoid which diverts oil to full bore or annular side of tele lift cylinder.	LCB
SW4	Function switch slew motor	Sends power to slew motor control solenoid which diverts oil to the left or right side of the slew motor.	LCB
SW5	Emergency stop button	Control circuit shut off. (In series with SW8)	LCB
SW6	Function switch Levelling	Sends power to Levelling control solenoid which diverts oil to the annular or full bore side of the slave levelling cylinder. It also sends power to the line contactor.	UCB
SW7	Switch - 4-Position selector	Sends power to selected solenoid valve (lower lift, upper lift, tele & slew). Only one function can be selected at one time.	UCB
SW8	Emergency stop button	Control circuit shut off.	UCB
SW9	Switch, Emergency Override	Provides emergency power when power is cut to the upper controls due to a tilt situation. It restricts power to one half of the selector switch SW7 allowing restricted movements of booms.	UCB
SW10	Switch, On/Off	Allows +48V supply to feed upper controls. Allows signals from lift functions to pass down to the controller. Allows Joystick trigger signal to pass down to the controller	UCB
SW11	Drive/lift switch	Switches to either drive or boom lift function	UCB
SW12	Horn switch	Activates horn in chassis	UCB
TAL	Tilt switch	This tilt alarm when level gives a constant supply back through the white cable and energises the tilt relay K1. When the machine is tilted supply is removed from the white cable.	Chassis

PUMP MOTOR CONTROL UNIT PIN LEGEND

PIN No.	DESCRIPTION
1	Battery Discharge Indicator (B.D.I.) output
2	Not used - sw8 - Switch 8
3	Not used - 10v Supply
4	sw4 - Switch 4 (Speed 4: Boom speeds from lower controls - Factory set at 40%)
5	Not used - Not connected
6	48V supply (Must be greater than 14 Volts)
7	sw5 - (Speed 5: Lower control slew speed - Factory set at 17%)
8	sw1 - Switch 1 (Speed 1: Max. Variable speed for Upper and Lower lift cylinders from upper controls - Factory set at 75 %)
9	Not used - Accel. supply
10	Not used - Not connected
11	sw7 - Switch 7 (Speed 7: Levelling speed from upper controls - Factory set at 20%)
12	sw3 - Switch 3 (Speed 3: Max. Variable speed for Tele cylinder from upper controls - Factory set at 100%)
13	sw2 - Switch 2 (Speed 2 : Max. Variable slewing speed from upper controls - Factory set at 38%)
14	Accelerator (3.5v-0v) - Input from joystick to vary motor speed from upper controls.
15	Not used - Not connected
16	sw6 - Switch 6 (Speed 6: Steer speed - Factory set at 40%)
17	Not used - Not connected

TRACTION MOTOR CONTROL UNIT PIN LEGEND

PIN No.	DESCRIPTION
1	Not used - Not connected
2	sw7 - Direction signal from tachometer generator.
3	Not used - Not connected
4	sw4 - Boom elevated signal
5	+48V supply
6	+48V supply
7	sw5 - Off level signal
8	sw1 - Forward direction signal from upper controls
9	Not used - Not connected
10	Not used - Not connected
11	sw2 - Reverse direction signal from upper controls
12	sw3 - Speed signal from Tacho circuitry
13	Not used - Not connected
14	Accelerator (3.5v-0v) - Input from joystick to vary motor speed from upper controls.
15	Signal to forward contactor
16	Not used - Not connected
17	Signal to reverse contactor

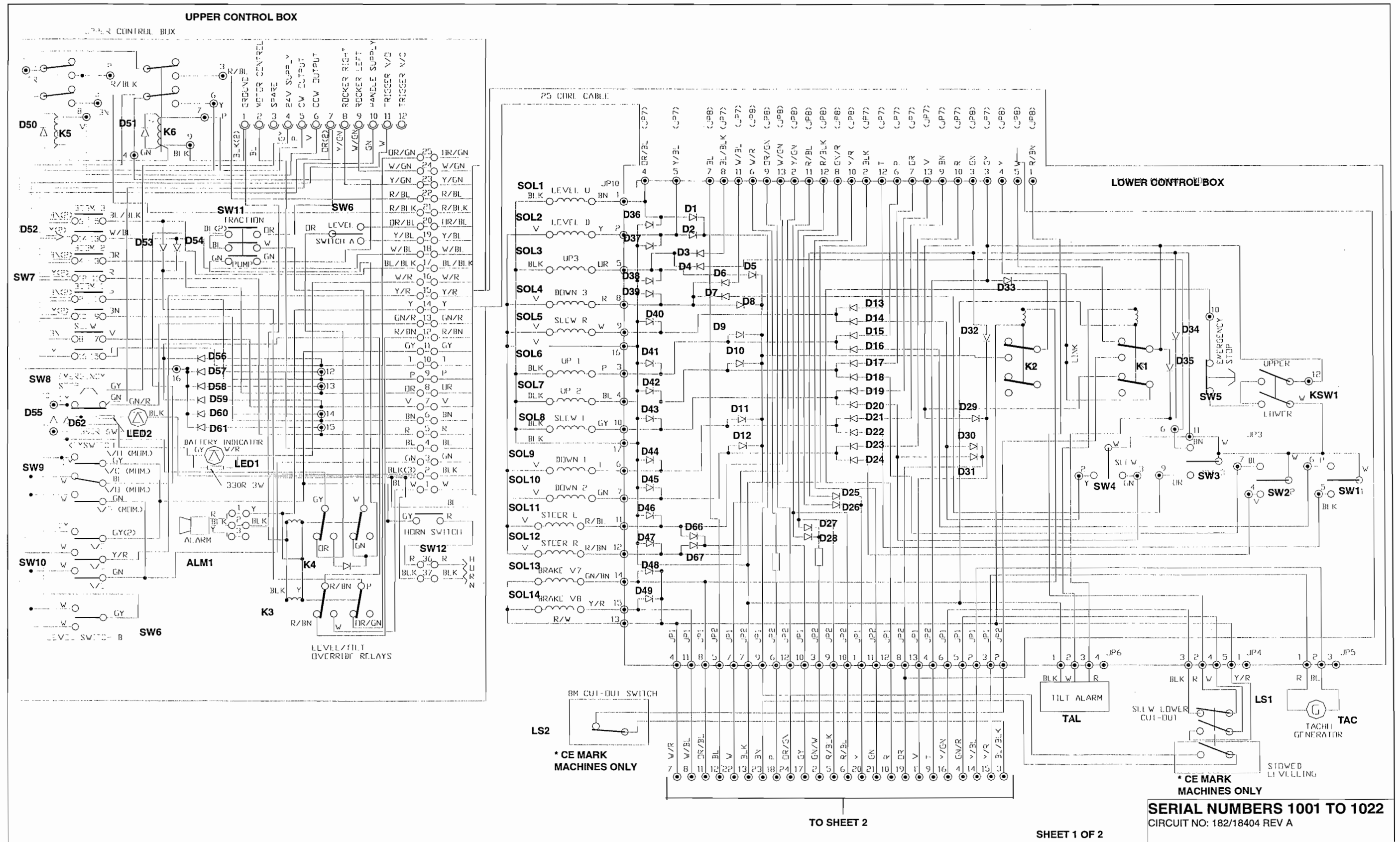

Schematics

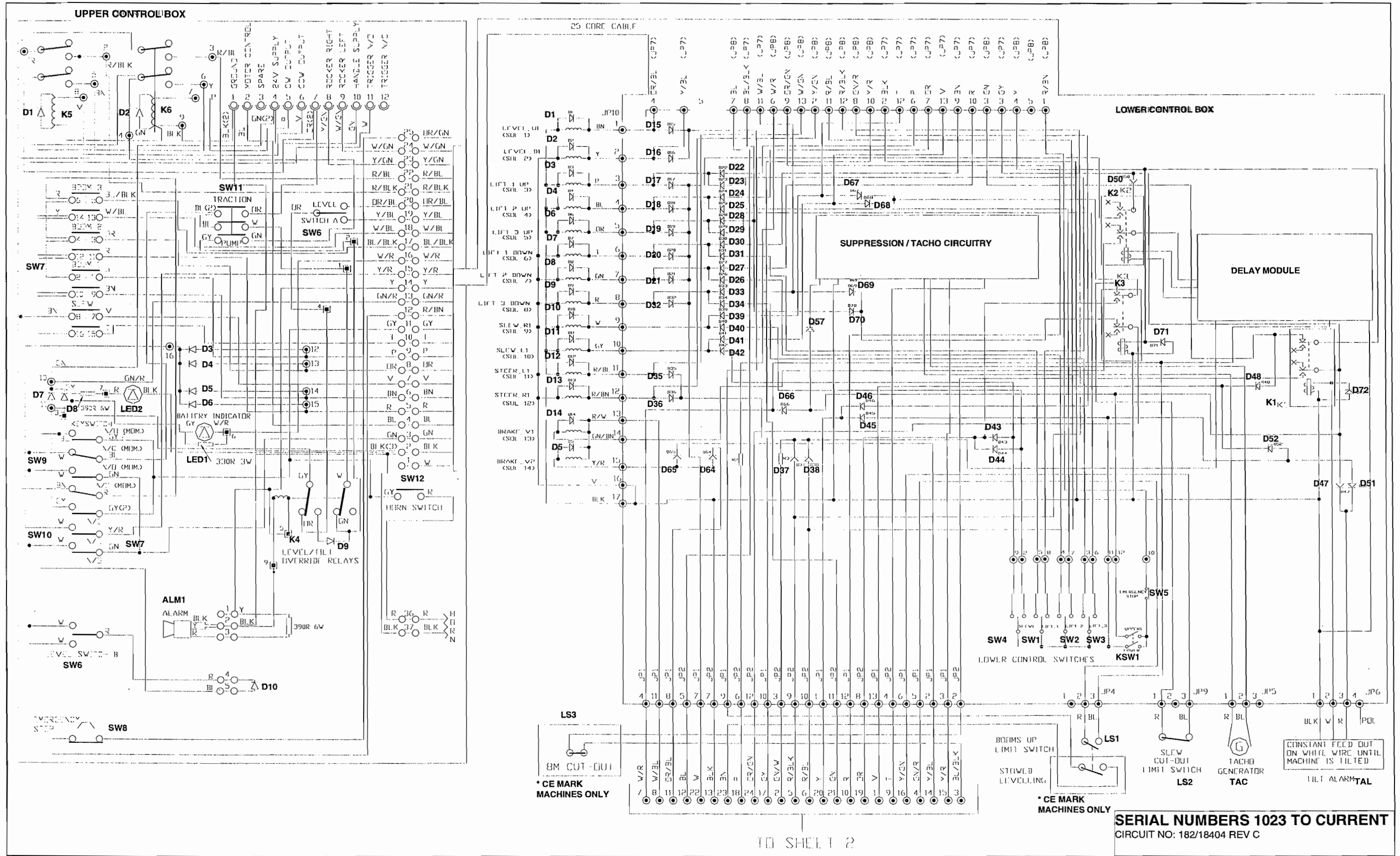

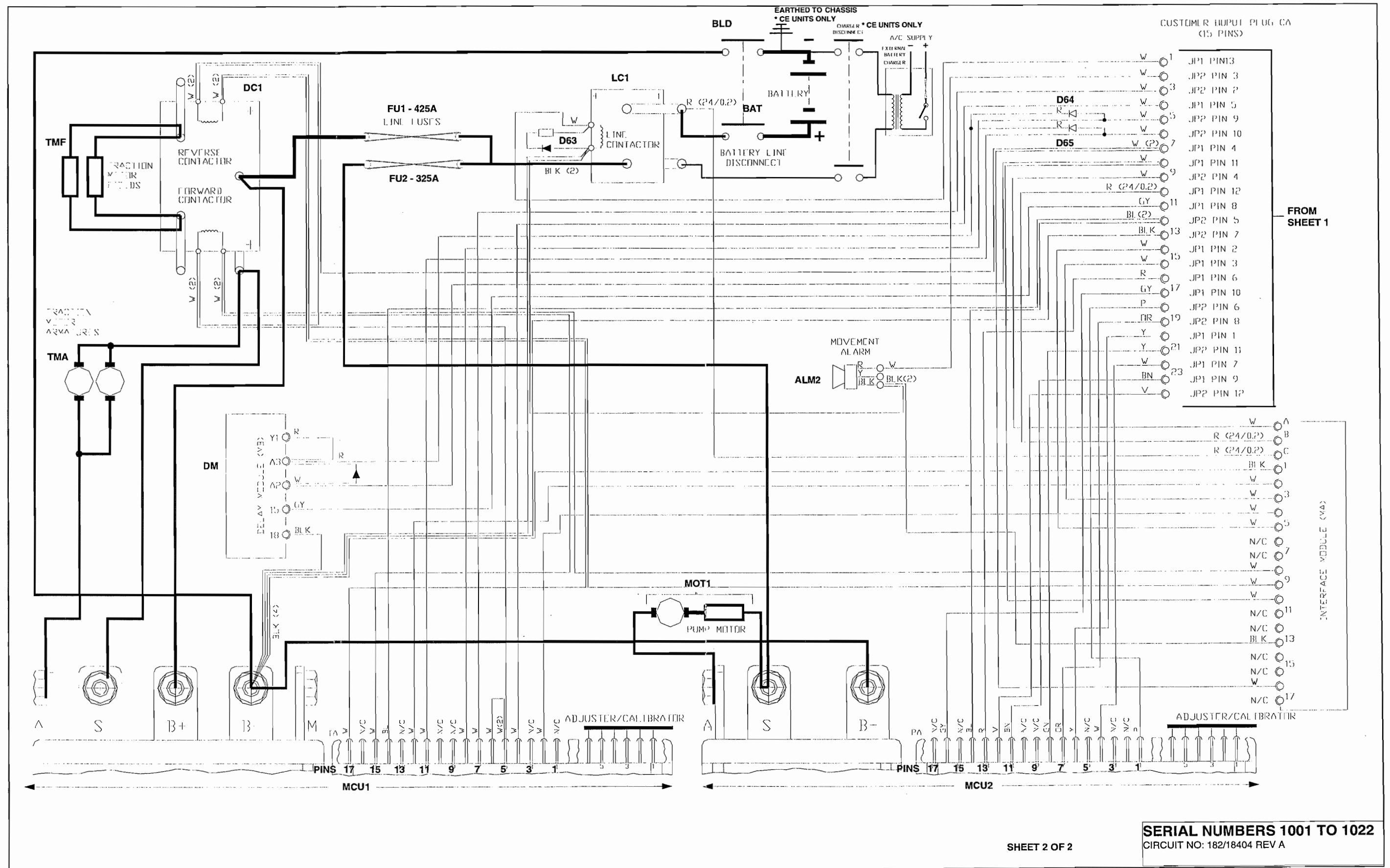

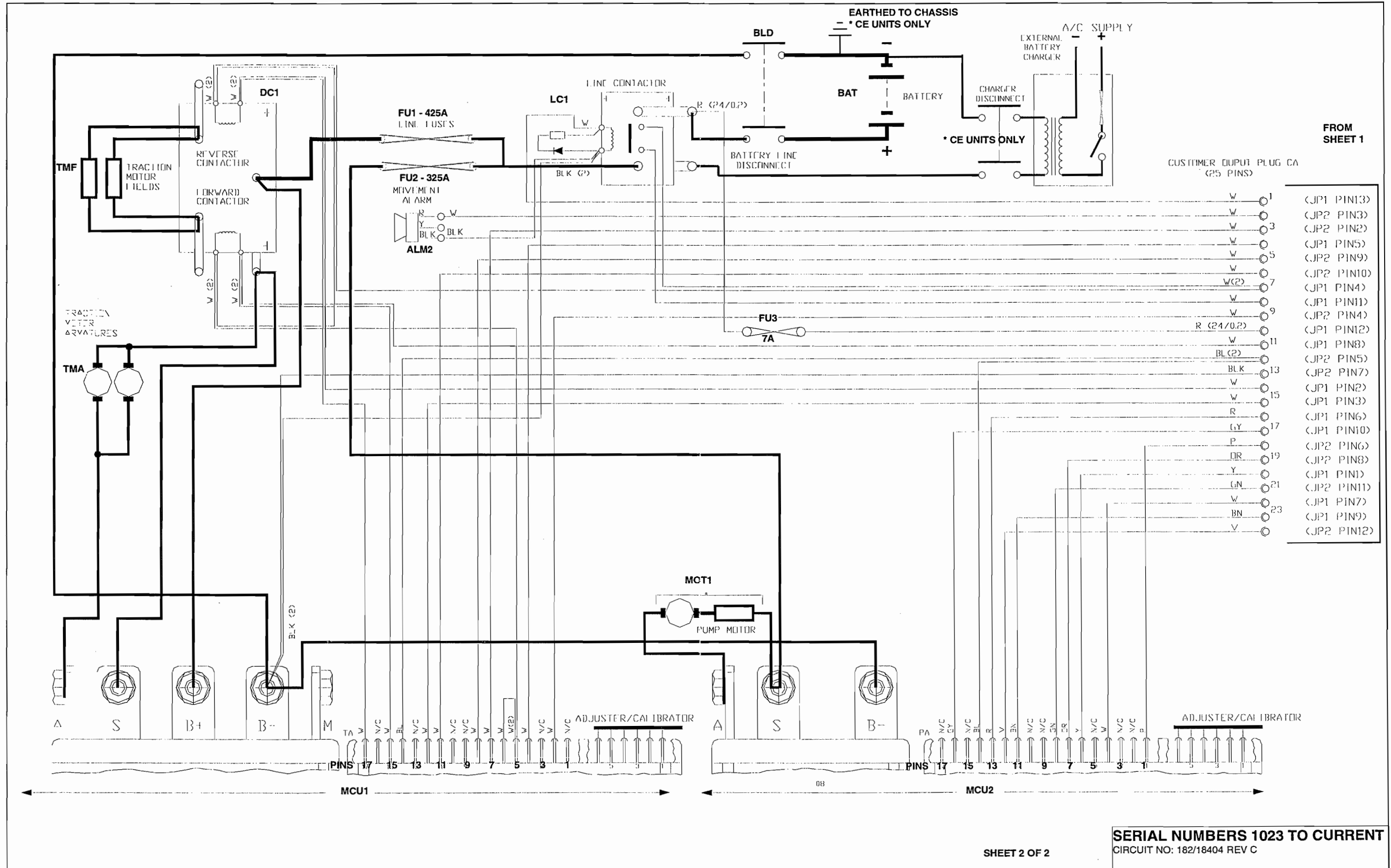

NOTES

6.2 Hydraulic Schematic

Table 6-2: Hydraulic Schematic Legend

REFERENCE	NAME	FUNCTION	LOCATION
BRK	Brake	Spring applied - Hydraulically released brakes to stop rotation of drive wheels	On front end of wheel drive motors on chassis.
CLRV	Cross-line relief valve	To limit the max. operating pressure of the slew motor. (Set at 50 Bar).	On main manifold block.
CV	Check Valve	To prevent oil pressure in the brake line from being lost through the main pressure line	On main manifold block
CYL1	Lower boom lift cylinder	Provides the force to lift lower boom	Foward of first post
CYL2	Upper boom lift cylinder	Provide the force to lift upper boom	Behind second post
CYL3	Tielscopic cylinder	Provides the force to push/pull the tele-boom	Inside upper outer & inner boom
CYL4	Steering cylinder	Provides the force to push/pull the steering rod.	Inside front of chassis
CYL5	Master levelling cylinder	Provides the pressure tothe slave cylinder for cage levelling	Behind second post
CYL6	Slave levelling cylinder	Provides the force to level cage up/down	Close to cage pivot at inner boom
FL1	Return line filter (10 Micron)	Continuously filters hydraulic return oil.	On top of hydraulic reservoir
HP	Handpump	Used for retraction of tele boom in the case of power failure. Delivers 15cc/stroke.	On side of hydraulic reservoir
MMB	Main manifold block	Contains the directional control valves and relief valves that distribute oil to the various functions and control the operating pressures.	On hydraulic reservoir in chassis.
MOT1	Slew Motor	Drives slew bearing pinion	Foward of first post on base plate
MP	Motor/Pump set	Gear pump close coupled to D.C electric motor. Provides pressurised oil flow for all hydraulic functions.	On chassis
SBV	Shutoff valve	Must be open for normal tele retraction. Must be open for non powered (Handpump) tele retraction.	Coupled to handpump
V1	Brake oil supply valve	This valve is energised to allow oil into the brake release chamber.	On main manifold block
V2	Brake valve	When energised this valve prevents the pressurised brake oil from venting back to tank. When the machine is stationary this valve de-energises and the brake oil vents to tank and the brake springs apply themselves and keep the machine stationary.	On main manifold block
V3	Pressure reduction valve	Prevents pressures in excess of 50 Bar entering the brake chambers.	On main manifold block
V4, V5, V6, V7, V8, V9	Directional Control Valves	Send oil to annular or full-bore sides of levelling,tele and lift cylinders and to the left or right side of the slew motor.	On main manifold block
V10	Main relief valve	Sets max system pressure to 145 Bar	On main manifold block
V11	Single overcentre valve	Prevents back flow and provides hydraulic lock on cylinder	On base of upper, lower & tele cylinders
V12	Emergency lowering valve	Allows upper and lower boom to be manually lowered	On base of upper and lower cylinders
V13	Pilot operated check valve	Holds tele cylinder in position after controls are released	On base of telecylinder
V14	Dual overcentre valve	Holds pressure in master/slave closed circuit and provides host burst protection. (Set 160 Bar)	On base of master cylinder
V15	Dual overcentre valve	Holds pressure in slave cylinder and provides host burst protection. (Set 120 Bar)	On base of slave cylinder

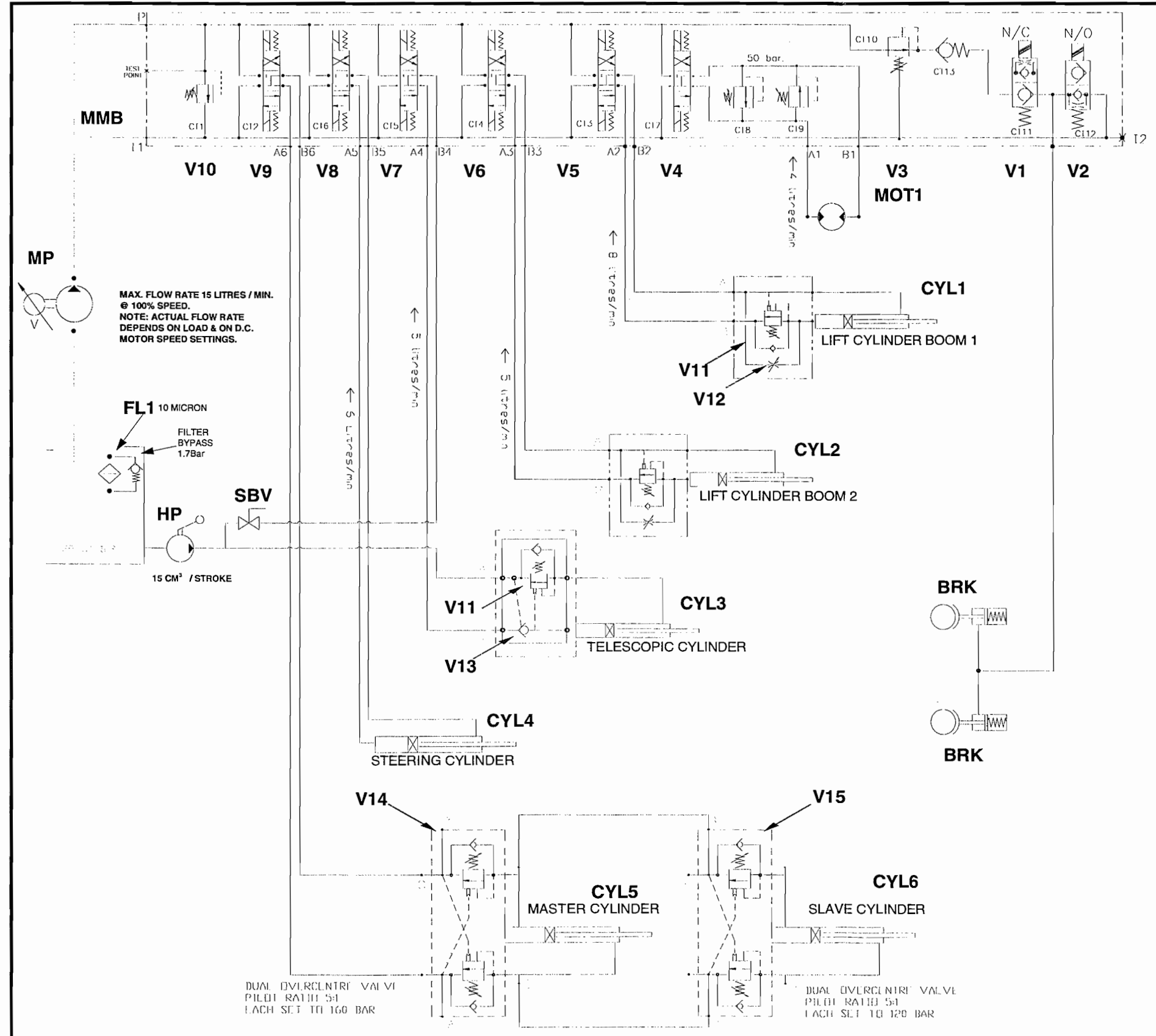

Figure 6-2: Hydraulic Schematic

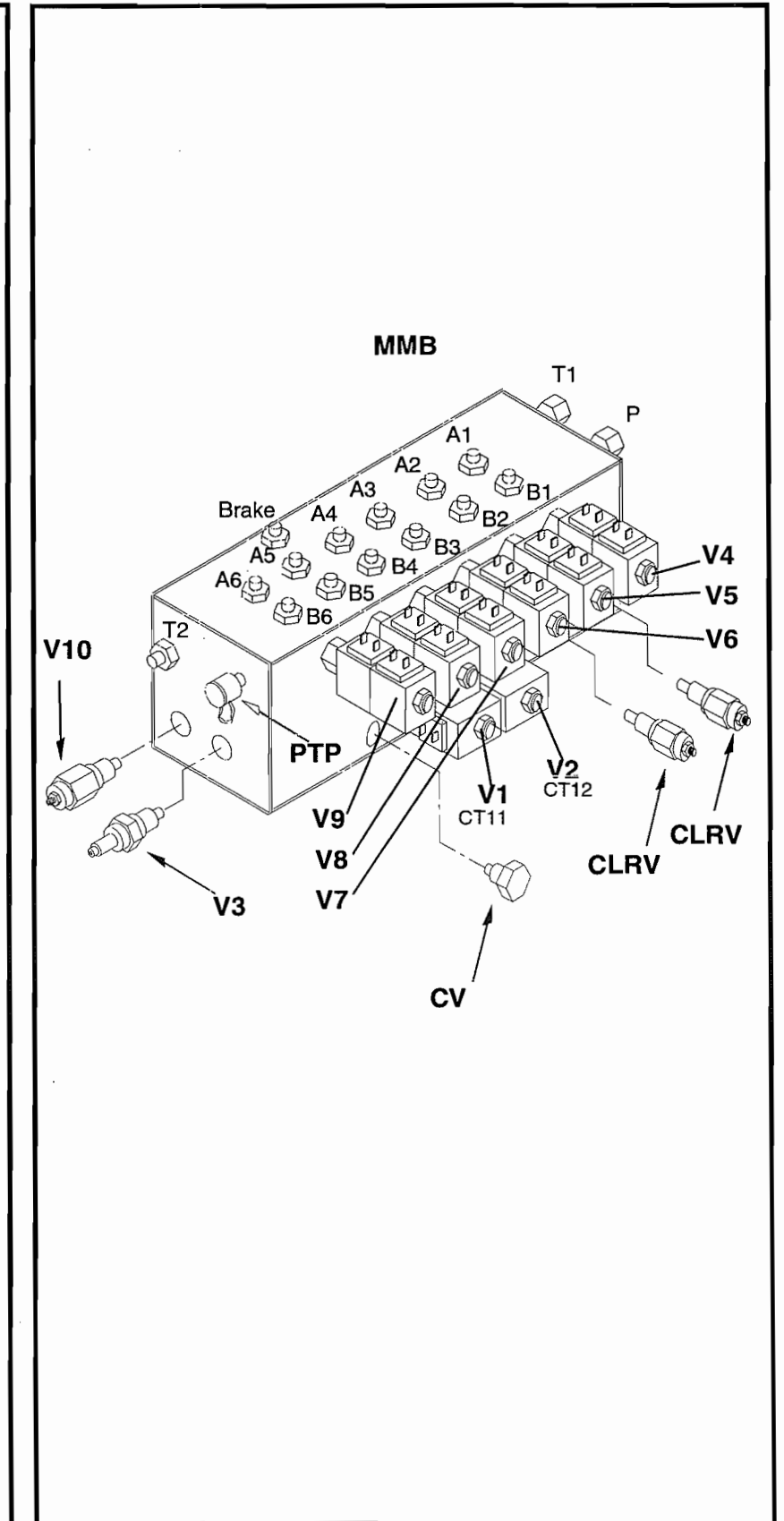

Figure 6-3: Hydraulic Manifolds

NOTES

A large, empty rectangular box with a black border, intended for handwritten notes or diagrams.

7.0 Introduction

This section lists and illustrates the replaceable assemblies and parts of the SP37 Work Platform as manufactured by UpRight Ireland Ltd.

Each parts list contains the component parts for that assembly indented to show relationship where applicable.

NOTE: Part Numbers and descriptions in bold text have more detailed descriptions further on in this manual.

7.1 Index

Assembly	Page
Chassis Assembly	7-2
Booms and Posts Assembly	7-4
Cage and Cradle Assembly	7-6
Slew Gear Box Assembly	7-8
Master/Slave Cylinder Assembly	7-10
Lower Lift Cylinder Assembly	7-12
Upper Lift Cylinder Assembly	7-14
Tele Cylinder Assembly	7-16
Motor Controller Assembly	7-18
Lower Control Box Assembly	7-20
Upper Control Box Assembly	7-22
Label Kit	7-24
Hose Assembly	7-26
Motor / Pump Assembly	7-28
Rear / Front Wheel Assemblies	7-30
Hydraulic Manifold Block Assembly	7-32
Steering Cylinder Assembly	7-34
Traction Motor Assembly	7-36
Drive Reduction Gearbox Assembly	7-38
Cables and Electrical Components	7-40

CHASSIS ASSEMBLY
58855-300

ITEM	PART-NUMBER	DESCRIPTION	QTY.
1	57611-200	CHASSIS WELDMENT	1
2	57644-300	MAIN CHASSIS BODY COVER	1
3	57643-300	MODULE COVER	2
4	57645-300	DRIVE MOTOR COVER	1
5	57760-300	HYDRAULIC RESERVOIR ASSY.	1
6	57944-000	HANDPUMP	1
*	58196-000	HANDLE FOR HANDPUMP	1
7	57535-300	HYDRAULIC MANIFOLD ASSY.	1
8	57530-000	HYDRAULIC MOTOR PUMP SET	1
9	57043-300	SLEW BEARING	1
10	57569-300	TACHOMETER	1
11	57568-300	DRIVE MOTOR R.H.	1
12	57580-300	DRIVE GEARBOX	2
13	57647-300	STEERING ARM	2
14	57745-300	STEERING ROD END PIN	2
15	58053-403	STEERING CYLINDER ROD END PIN	1
16	57682-300	STEERING CYLINDER ASSY.	1
17	58053-402	STEERING CYLINDER BODY END PIN	1
18	57669-300	STEERING STUB AXLE ASSEMBLY	2
19	57667-300	FRONT WHEEL ASSEMBLY	2
20	57579-000	FRONT WHEEL NUT - M16	10
21	57573-300	BATTERY CHARGER	1
22	15796-001	BATTERY 6V	8
23	57591-000	LOWER CONTROL BOX SERIAL NUMBERS 1001 TO 1022	1
*	57592-000	LOWER CONTROL BOX SERIAL NUMBERS 1023 TO 1035	1
*	57593-000	LOWER CONTROL BOX SERIAL NUMBERS 1036 TO 1074	1
*	57594-000	LOWER CONTROL BOX SERIAL NUMBERS 1075 TO CURRENT	1
24	57570-000	TACHOMETER ADAPTOR KIT	1
25	58992-300	MOTOR CONTROLER ASSEMBLY	1
26	57619-300	STEERING ROD	1
27	57281-400	TILT SENSOR	1
28	58834-300	DRIVE MOTOR L.H.	1
29	57668-300	REAR WHEEL ASSEMBLY	2
30	57578-000	REAR WHEEL NUT - M14	10

Illustrated parts breakdown

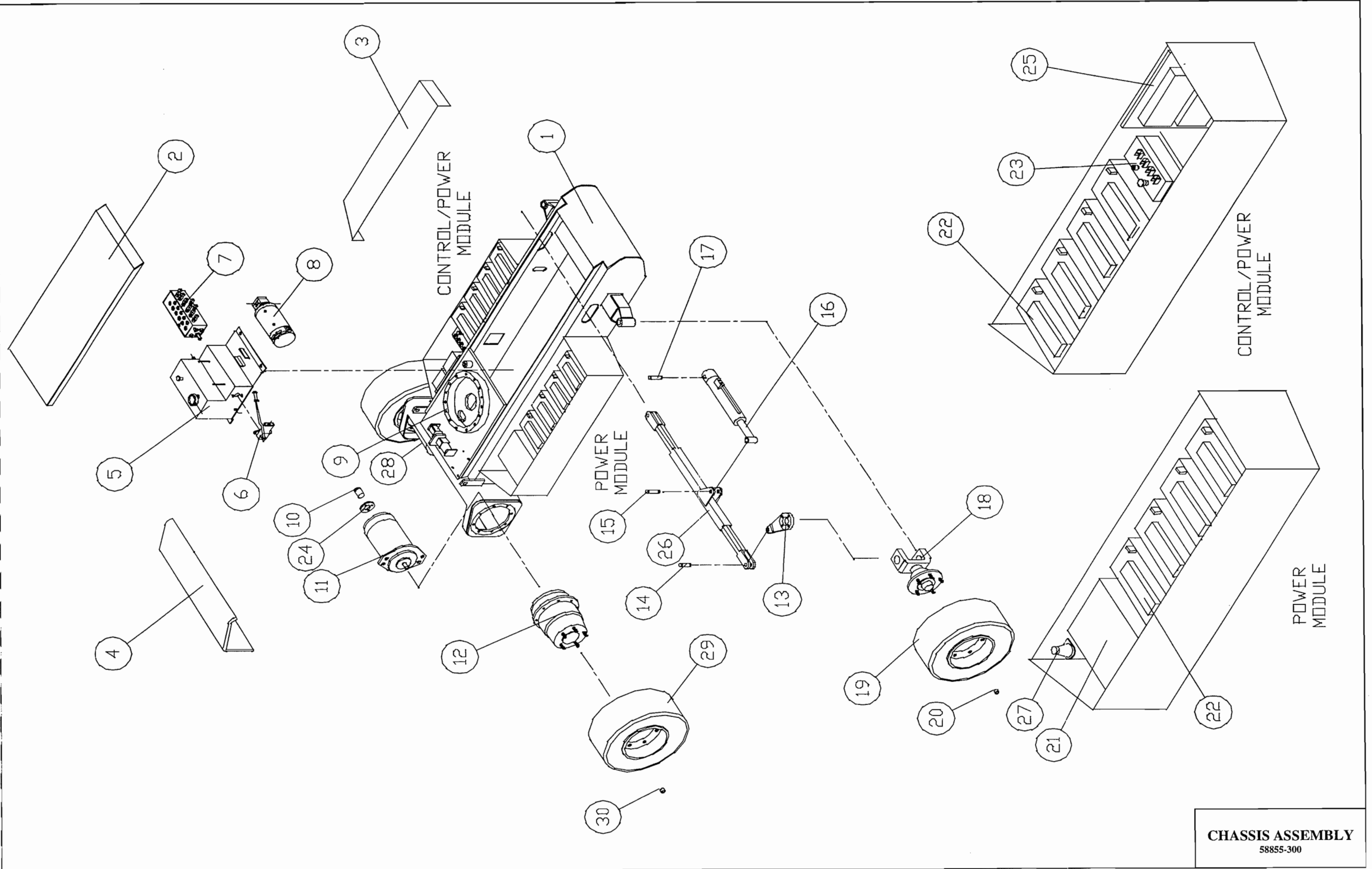

BOOMS AND POSTS ASSEMBLY
58856-300

ITEM	PART-NUMBER	DESCRIPTION	QTY.
1	57612-300	FIRST POST WELDMENT	1
2	57616-300	TENSION BAR WELDMENT	2
3	57613-300	LOWER BOOM WELDMENT	1
4	57813-300	SECOND POST WELDMENT	1
5	57614-300	UPPER BOOM WELDMENT	1
6	57615-300	INNER BOOM WELDMENT	1
7	57683-000	TELE CYLINDER ASSEMBLY	1
8	57676-300	TRUNKING	1
9	57677-300	TRUNKING COVER	1
10	57678-300	ENERGY CHAIN GUIDE	1
11	57679-000	ENERGY CHAIN	1
*	58821-000	LINK ASSY (SIDES AND CROSSBARS)	1
*	58822-000	MOUNTING ELEMENTS (SET OF 4)	1
12	58058-300	CHAIN SUPPORT CHANNEL	1
13	57982-000	1ST POST CYLINDER ASSY	1
14	57983-000	2ND POST CYLINDER ASSY	1
15	57980-000	MASTER CYLINDER ASSY	1
16	57047-000	25MM I.D. BUSHING	4
17	58054-401	PIN 30MM	2
18	57041-300	SLEW GEARBOX AND PINION ASSEMBLY	1
19	58066-402	PIN 30MM	1
20	57977-300	WEAR PAD (SIDE)	2
21	57054-000	30MM I.D. FLANGED BUSH	4
22	58056-400	PIN LOCK PLATE	16
23	57976-300	OUTER BOOM WEAR PAD	2
24	57975-300	INNER BOOM WEAR PAD	2
25	57046-000	35MM I.D. BUSHING	8
26	58055-404	PIVOT PIN 35MM	1
27	57885-300	WEAR PAD COVER PLATE	2
28	58066-403	PIVOT PIN 30MM	1
29	58054-402	PIN 30MM	2
30	57033-000	CIRCLIP	4
31	58065-402	PIN 25MM	1
32	58065-404	PIN 25MM	1
33	58065-403	PIN 25MM	1
34	57350-300	SLEW MOTOR	1
35	58055-403	PIVOT PIN 35MM	1

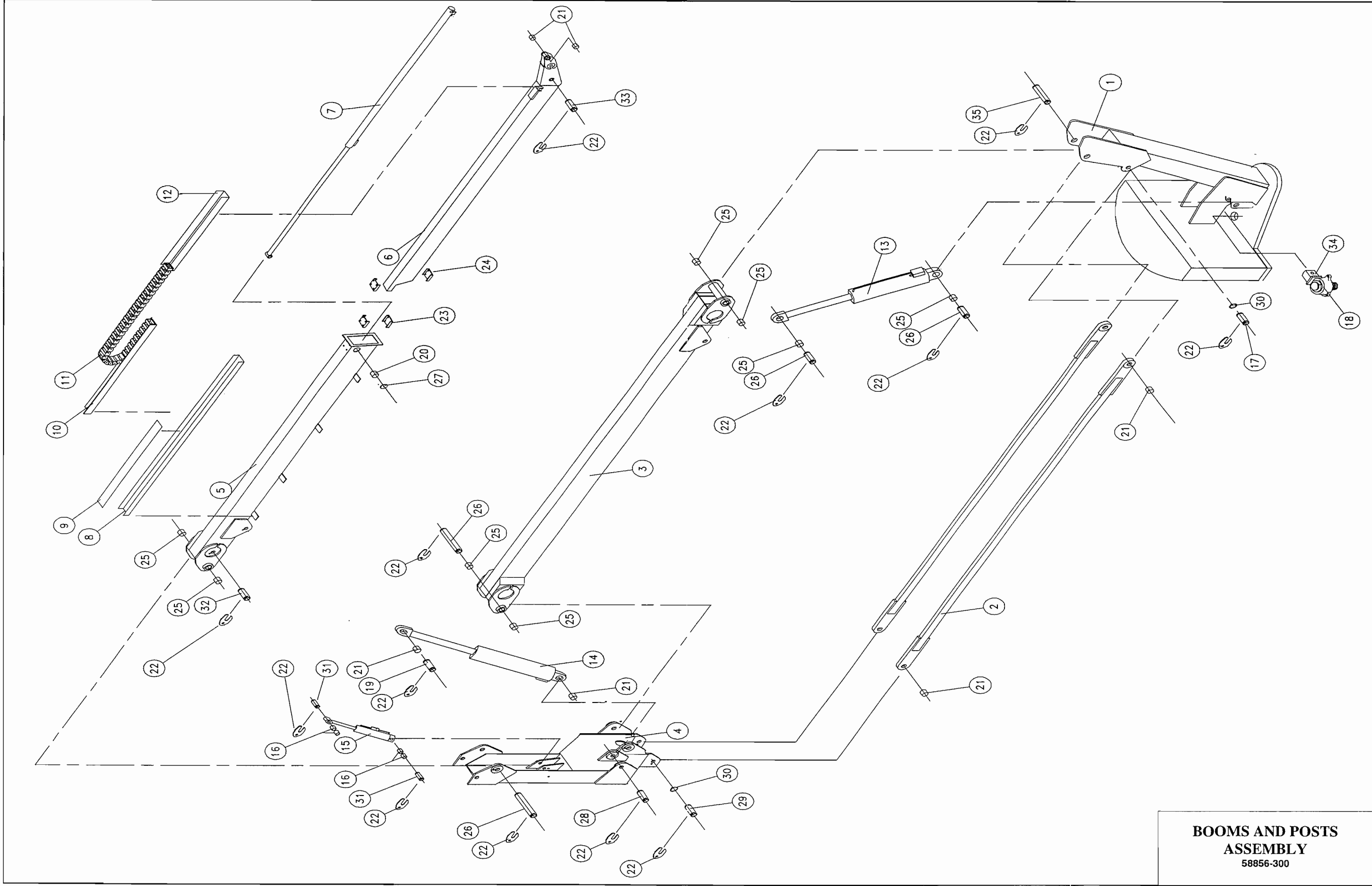

CAGE AND CRADLE ASSEMBLY
58857-300

ITEM	PART-NUMBER	DESCRIPTION	QTY.
1	57620-300	CAGE RAIL WELDMENT	1
2	57994-300	CAGE FLOOR WELDMENT	1
3	57765-300	KICKER PLATE WELDMENT	1
4	57992-300	CAGE BASE WELDMENT	1
5	57821-300	CRADLE WELDMENT	1
6	57981-300	SLAVE CYLINDER ASSEMBLY	1
7	57572-300	UPPER CONTROL BOX ASSEMBLY	1
8	58038-400	UPPER CONTROL BOX MOUNTING BRACKET	1
9	57767-300	MOUNTING PANEL	1
10	03613-000	INSTRUCTION HOLDER	1
11	58056-400	PIN LOCK PLATE	3
12	58065-401	PIN	1
13	58053-400	PIN	1
14	57054-000	BUSHING	2
15	57032-000	25MM EXTERNAL CIRCLIP	1
16	58066-401	PIN	1
17	57675-300	STEP ASSEMBLY	1
18	57047-000	25MM I.D. BUSHING	4

CAGE AND CRADLE

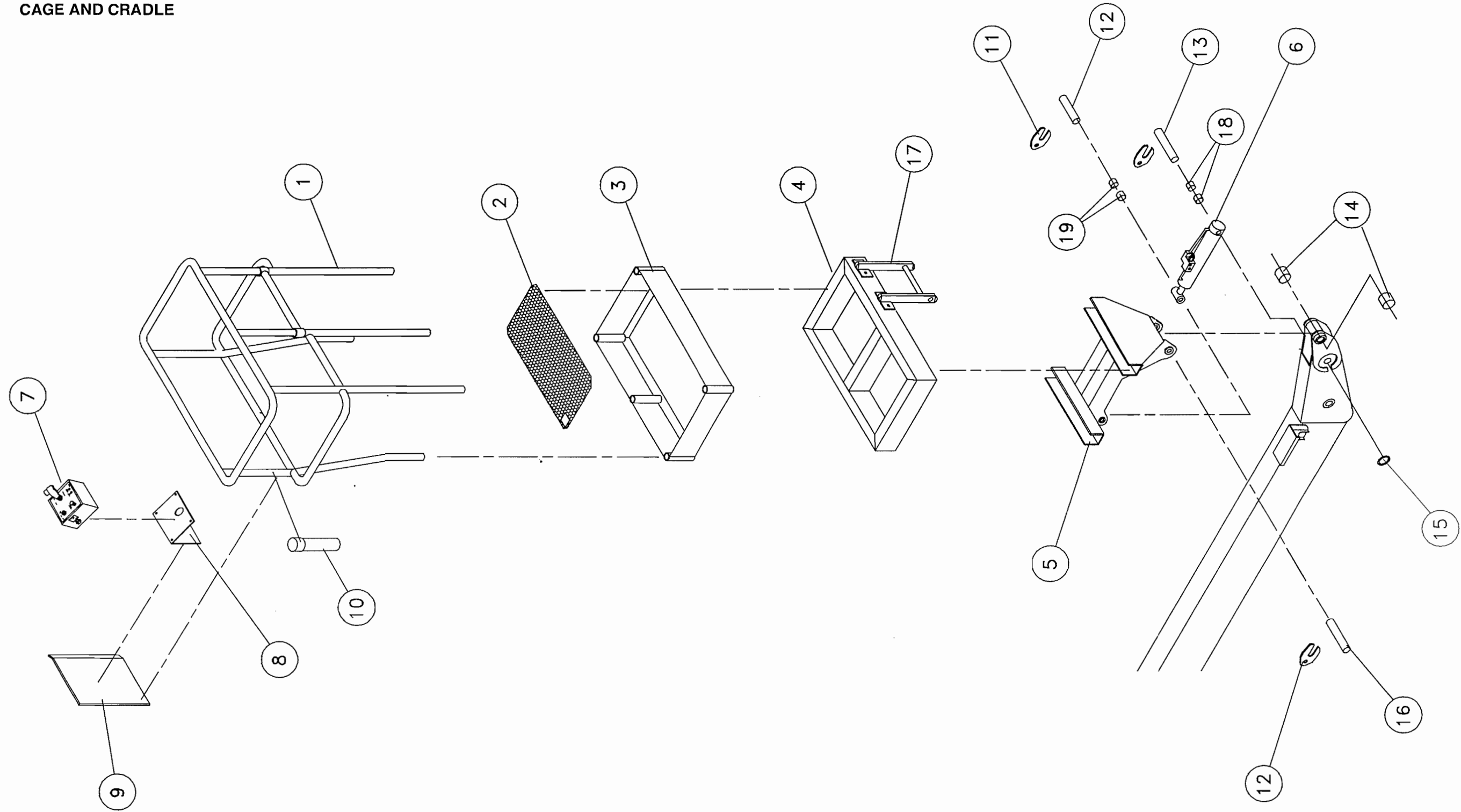

CAGE AND CRADLE
ASSEMBLY
58857-300

SLEW GEARBOX ASSEMBLY
57041-300

ITEM	PART-NUMBER	DESCRIPTION	QTY.
1	-	GEARBOX HOUSING	1
2	-	BEARING HOUSING	1
3	-	TOP CAP	1
4	-	WORM CAP	1
5	-	GEAR WHEEL	1
6	-	WORM	1
7	-	MAIN SHAFT	1
8	-	SLEW PINION	1
9	-	BUSH	1
10	-	LOCKING CAP	1
11	-	STUD	1
12	-	SELF-LOCKING NUT	1
13	-	KEY	1
14	-	KEY	1
15	-	BEARING	1
16	-	CIRCLIP	1
17	-	SEAL	1
18	-	BEARING	1
19	-	CIRCLIP	1
20	-	SEAL	1
21	-	SEALOCK PIN	1
22	-	CIRCLIP	1
23	-	BEARING	1
24	-	CIRCLIP	1
25	-	BEARING	1
26	-	SEAL	1
27	-	CIRCLIP	1

SLEW GEARBOX ASSEMBLY

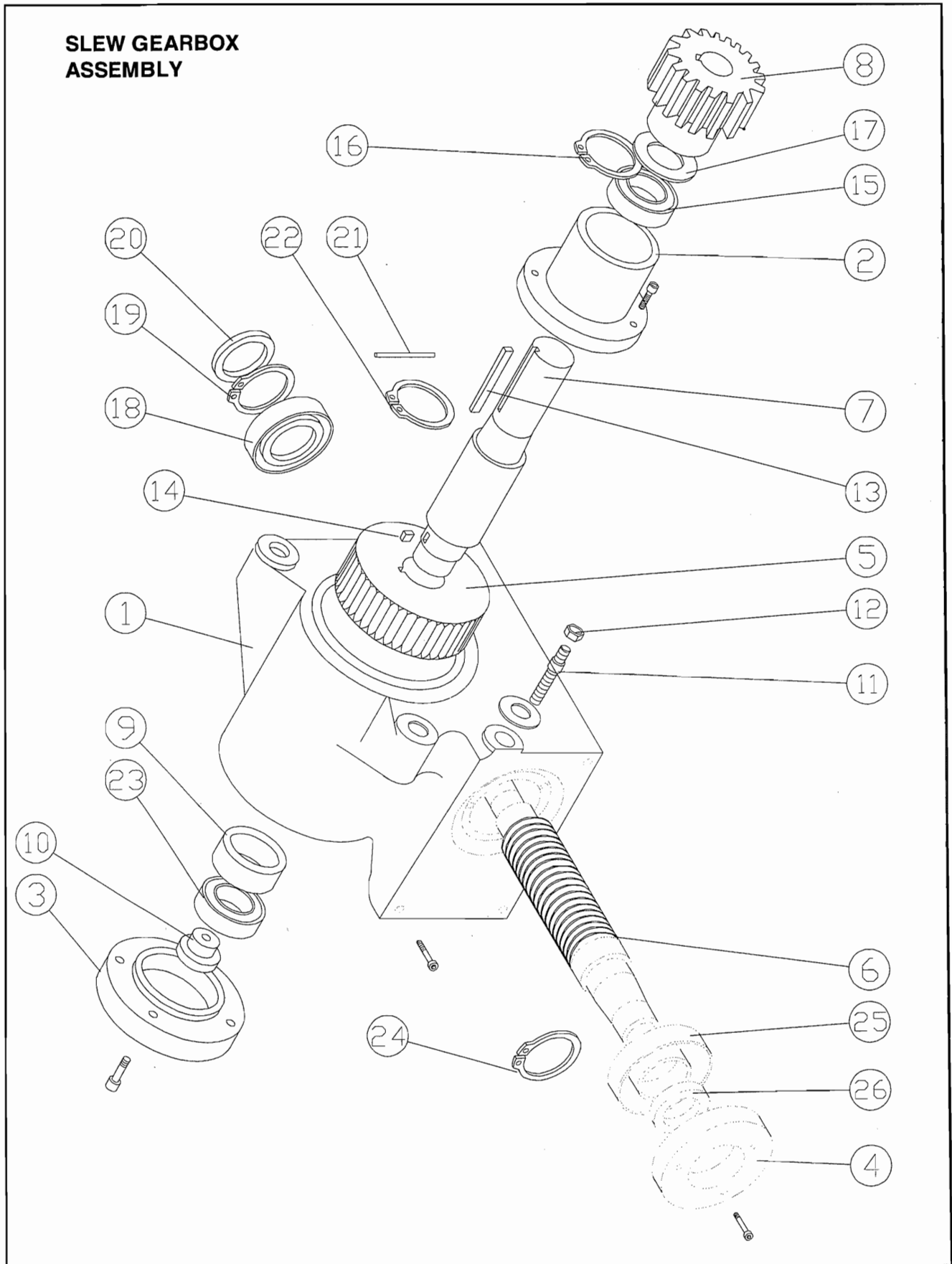

MASTER/SLAVE CYLINDER ASSEMBLY
58734-300/58735-300

ITEM	PART-NUMBER	DESCRIPTION	QTY.
1	-	MASTER/SLAVE CYLINDER BODY	1
2	-	VALVE BODY	1
3	58715-000	SINGLE OVERCENTRE CARTRIDGE - SLAVE - 120 BAR	1
	58719-000	SINGLE OVERCENTRE CARTRIDGE - MASTER - 160 BAR	1
4	-	END CAP	1
5	-	ROD AND END PIVOT	1
6	SEE NOTE	ROD SEAL	2
7	SEE NOTE	O-RING	1
8	SEE NOTE	WIPER	1
9	SEE NOTE	PISTON O-RING	1
10	58819-000	GREASE NIPPLE	2
11	-	PISTON HEAD	1
12	SEE NOTE	PISTON SEAL	1
13	-	PISTON LOCKNUT	1
14	SEE NOTE	ROLL PIN	1
15	SEE NOTE	GRUB SCREW	1
16	SEE NOTE	END CAP GLAND	1
17	-	TAB WASHER	1

NOTE: ITEMS 6,7,8,9,12,13,14,15 & 16 ALL FORM THE SEAL KIT FOR THE CYLINDER.
THE SEAL KIT IS PART NUMBER 58750-000

Master and Slave Cylinder Assembly

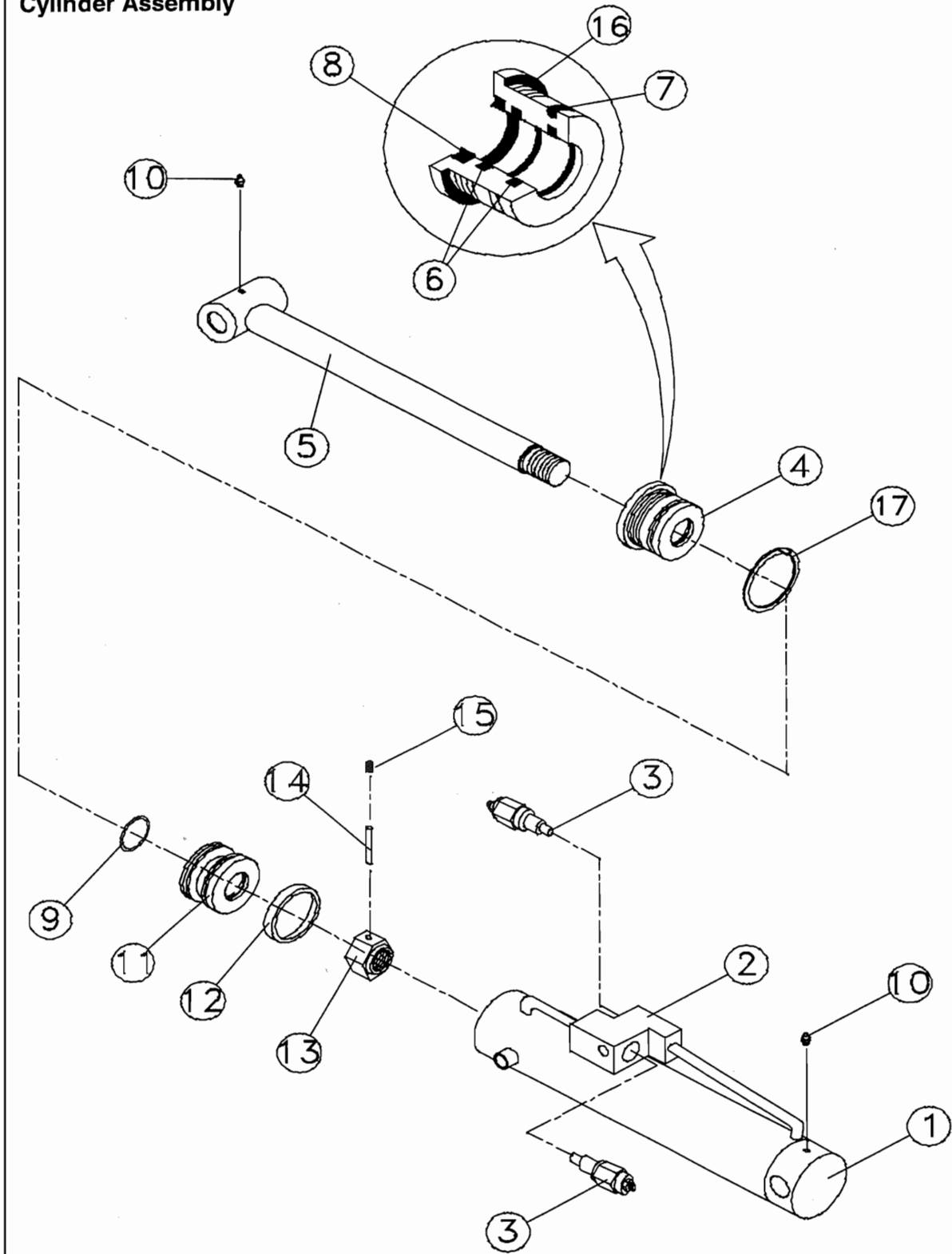

LOWER LIFT CYLINDER ASSEMBLY
57680-300

ITEM	PART-NUMBER	DESCRIPTION	QTY.
1	-	CYLINDER BODY	1
2	-	VALVE BODY WELDED TO CYLINDER	1
3	58884-000	EMERGENCY LOWERING CARTRIDGE VALVE	1
4	-	END CAP	1
5	-	ROD AND END PIVOT	1
6	SEE NOTE	ROD SEAL	2
7	SEE NOTE	O-RING	1
8	SEE NOTE	WIPER	1
9	SEE NOTE	PISTON O-RING	1
10	58819-000	GREASE NIPPLE	2
11	-	PISTON HEAD	1
12	SEE NOTE	PISTON SEAL	1
13	SEE NOTE	PISTON LOCKNUT	1
16	SEE NOTE	END CAP GLAND	1
17	-	TAB WASHER	1
18	58728-000	SINGLE OVERCENTRE CARTRIDGE - 175 BAR	1
19	SEE NOTE	END CAP SEAL	1
20	-	CUSHIONING SPRING	1
21	-	CUSHIONING SHAFT	1
22	-	SLEEVE	1
23	-	RETAINING CLIP	1

NOTE: ITEMS 6,7,8,9,12,13 & 16 ALL FORM THE SEAL KIT FOR THE CYLINDER.
THE SEAL KIT IS PART NUMBER 58746-000

Lower Lift Cylinder Assembly

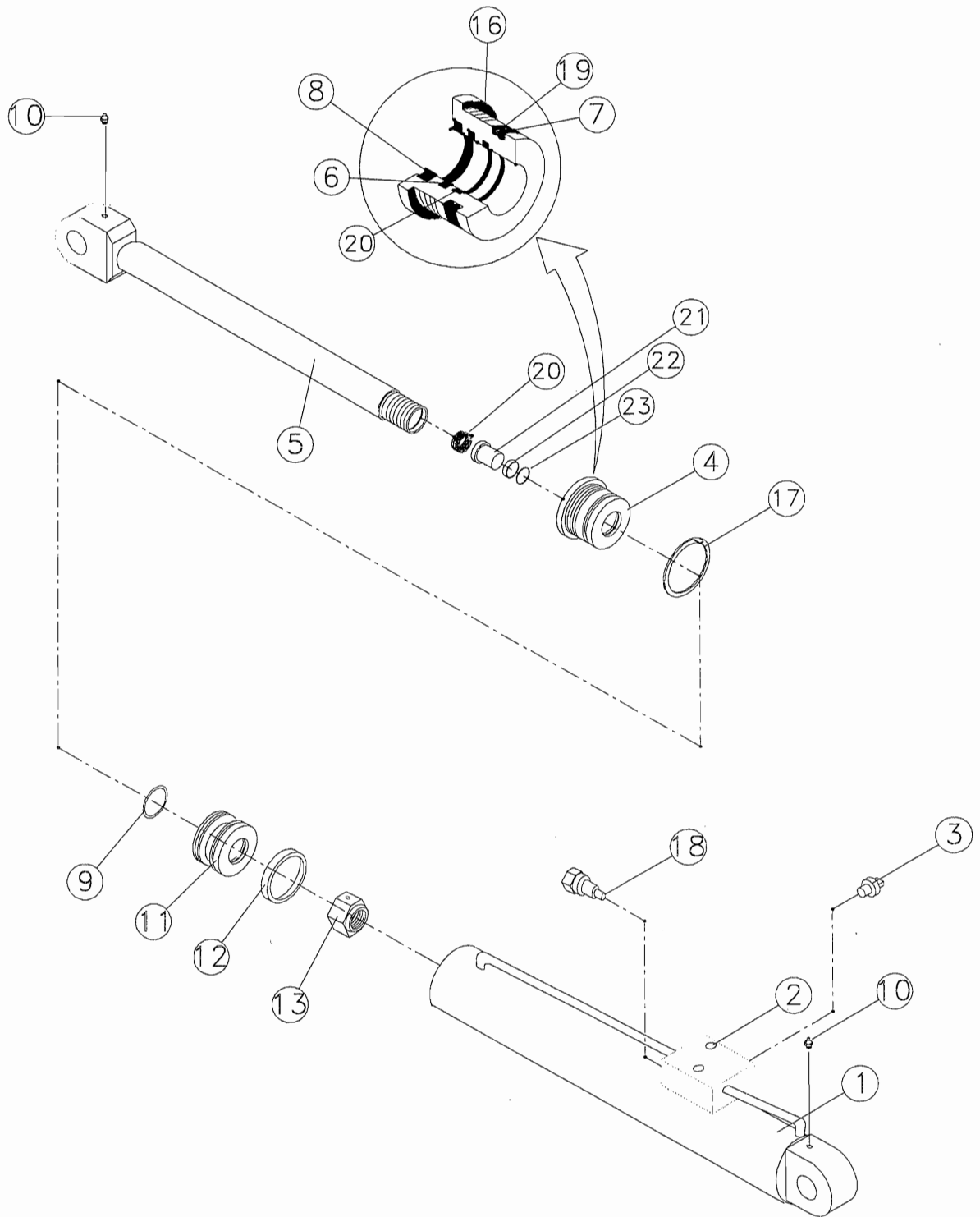

UPPER LIFT CYLINDER ASSEMBLY
58681-300

ITEM	PART-NUMBER	DESCRIPTION	QTY.
1	-	CYLINDER BODY	1
2	-	VALVE BODY WELDED TO CYLINDER	1
3	58884-000	EMERGENCY LOWERING CARTRIDGE VALVE	1
4	-	END CAP	1
5	-	ROD AND END PIVOT	1
6	SEE NOTE	ROD SEAL	2
7	SEE NOTE	O-RING	1
8	SEE NOTE	WIPER	1
9	SEE NOTE	PISTON O-RING	1
10	58819-000	GREASE NIPPLE	2
11	-	PISTON HEAD	1
12	SEE NOTE	PISTON SEAL	1
13	SEE NOTE	PISTON LOCKNUT	1
16	SEE NOTE	END CAP GLAND	1
17	-	TAB WASHER	1
18	58728-000	SINGLE OVERCENTRE CARTRIDGE - 175 BAR	1
19	SEE NOTE	END CAP SEAL	1
20	-	CUSHIONING SPRING	1
21	-	CUSHIONING SHAFT	1
22	-	SLEEVE	1
23	-	RETAINING CLIP	1

NOTE: ITEMS 6,7,8,9,12,13 & 16 ALL FORM THE SEAL KIT FOR THE CYLINDER.
THE SEAL KIT IS PART NUMBER 58747-000

Upper Lift Cylinder Assembly

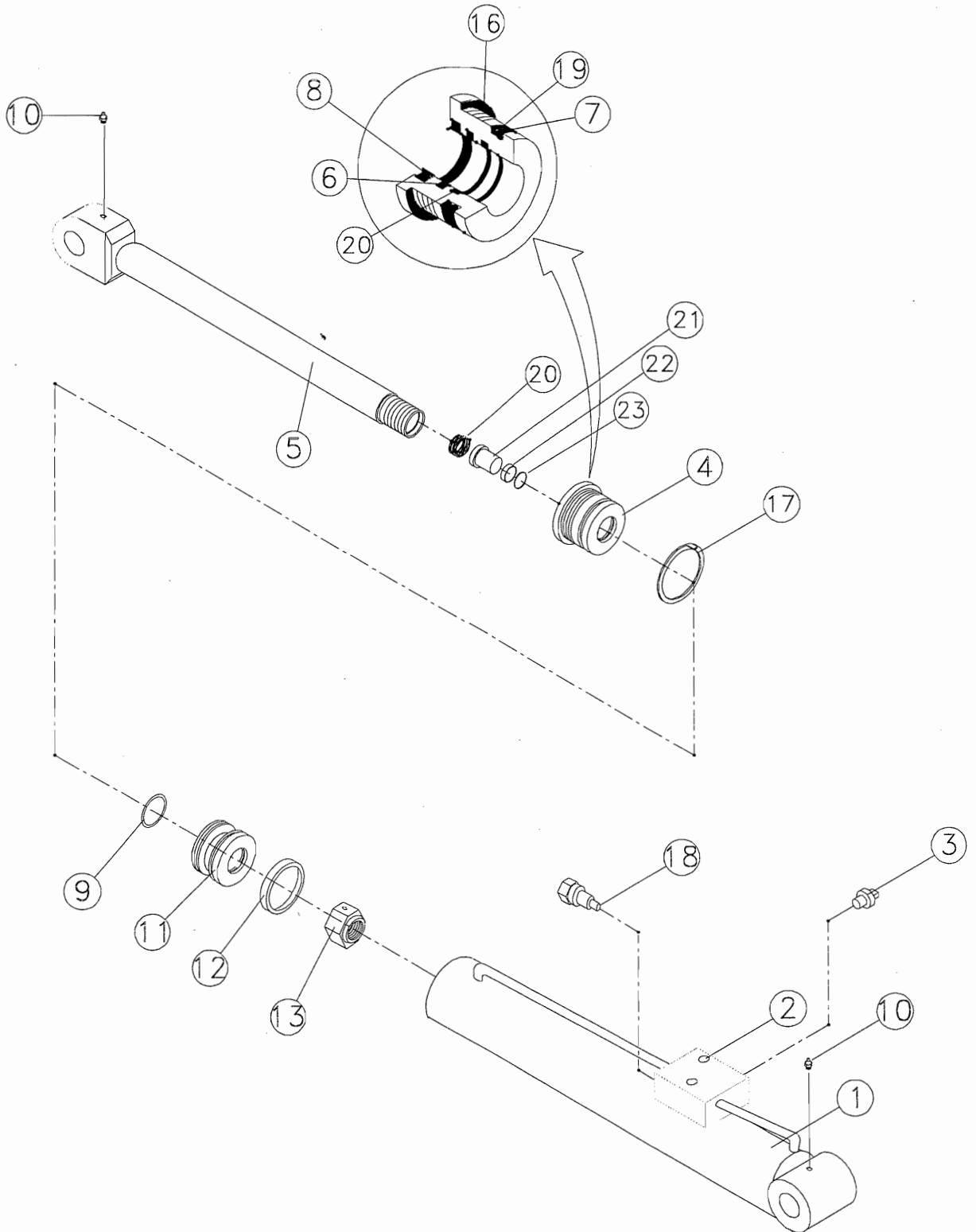

TELE CYLINDER ASSEMBLY
57683-300

ITEM	PART-NUMBER	DESCRIPTION	QTY.
1	-	TELE CYLINDER BODY	1
2	-	VALVE BODY	1
3	58728-000	SINGLE OVERCENTRE CARTRIDGE - 175 BAR	1
4	-	END CAP	1
5	-	ROD AND END PIVOT	1
6	SEE NOTE	ROD SEAL	2
7	SEE NOTE	O-RING	1
8	SEE NOTE	WIPER	1
9	SEE NOTE	PISTON O-RING	1
10	58819-000	GREASE NIPPLE	2
11	-	PISTON HEAD	1
12	SEE NOTE	PISTON SEAL	1
13	SEE NOTE	PISTON LOCKNUT	1
14	SEE NOTE	ROLL PIN	1
15	SEE NOTE	GRUB SCREW	1
16	SEE NOTE	END CAP GLAND	1
17	-	TAB WASHER	1
18	58714-000	SINGLE P.O. CHECK CARTRIDGE	1

NOTE: ITEMS 6,7,8,9,12,13,14,15 & 16 ALL FORM THE SEAL KIT FOR THE CYLINDER.
THE SEAL KIT IS PART NUMBER 58748-000

Telescopic Cylinder Assembly

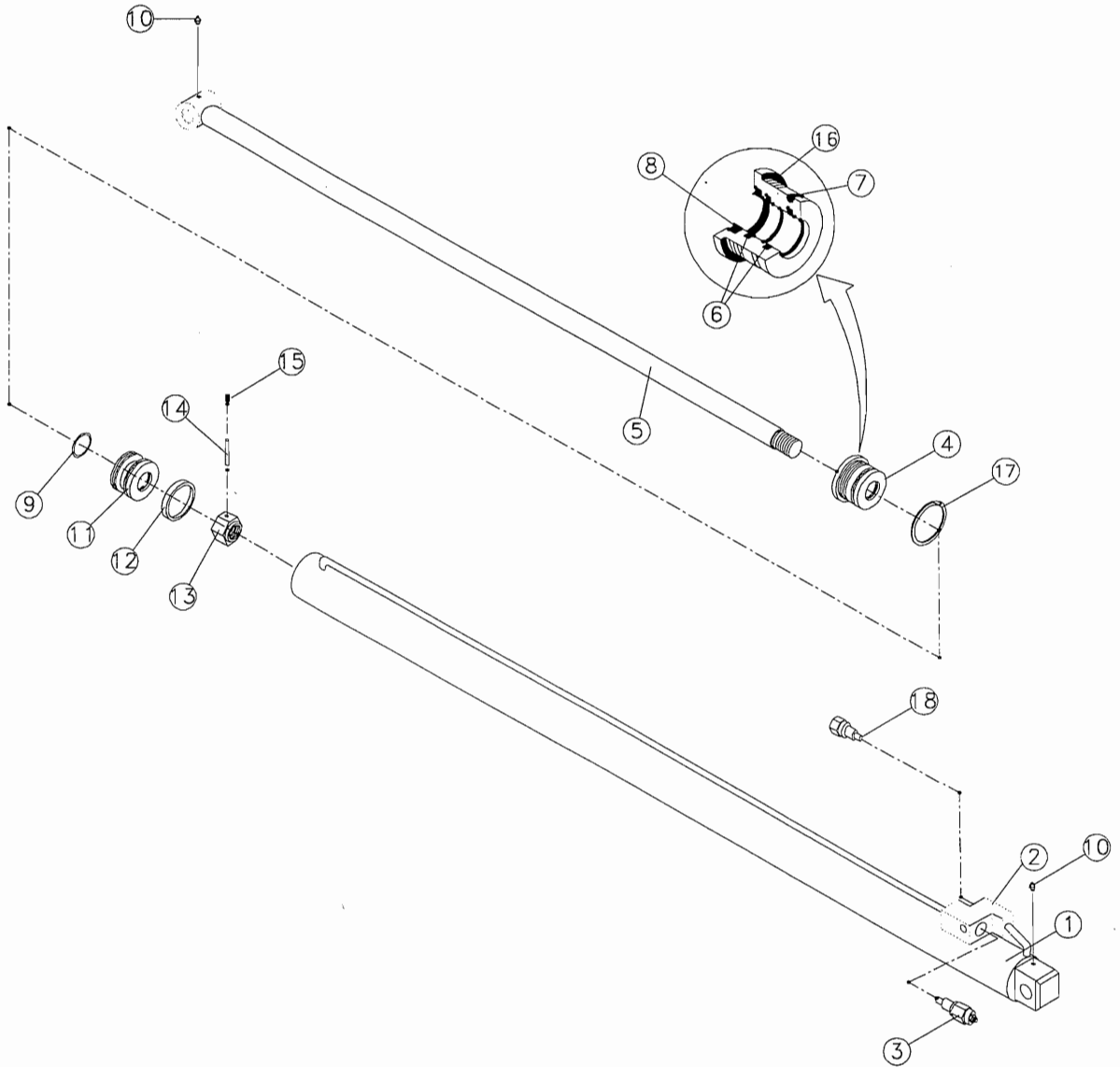

MOTOR CONTROLLER ASSEMBLY
58915-300

ITEM	PART-NUMBER	DESCRIPTION	QTY.
1	57590-000	TRACTION MOTOR CONTROLLER	1
2	57598-000	PUMP MOTOR CONTROLLER	1
3	58917-000	FORWARD / REVERSE CONTACTOR	1
4	58916-000	PUMP CONTACTOR	1
5	57328-000	BUZZER	1
6	58921-000	PUMP FUSE - 325A	1
7	58920-000	TRACTION - 425A	1
8 * NOT SHOWN	57128-000	MOS 90 CALIBRATOR - TEST / PROGRAMMING INSTRUMENT	1

Motor Controller Assembly

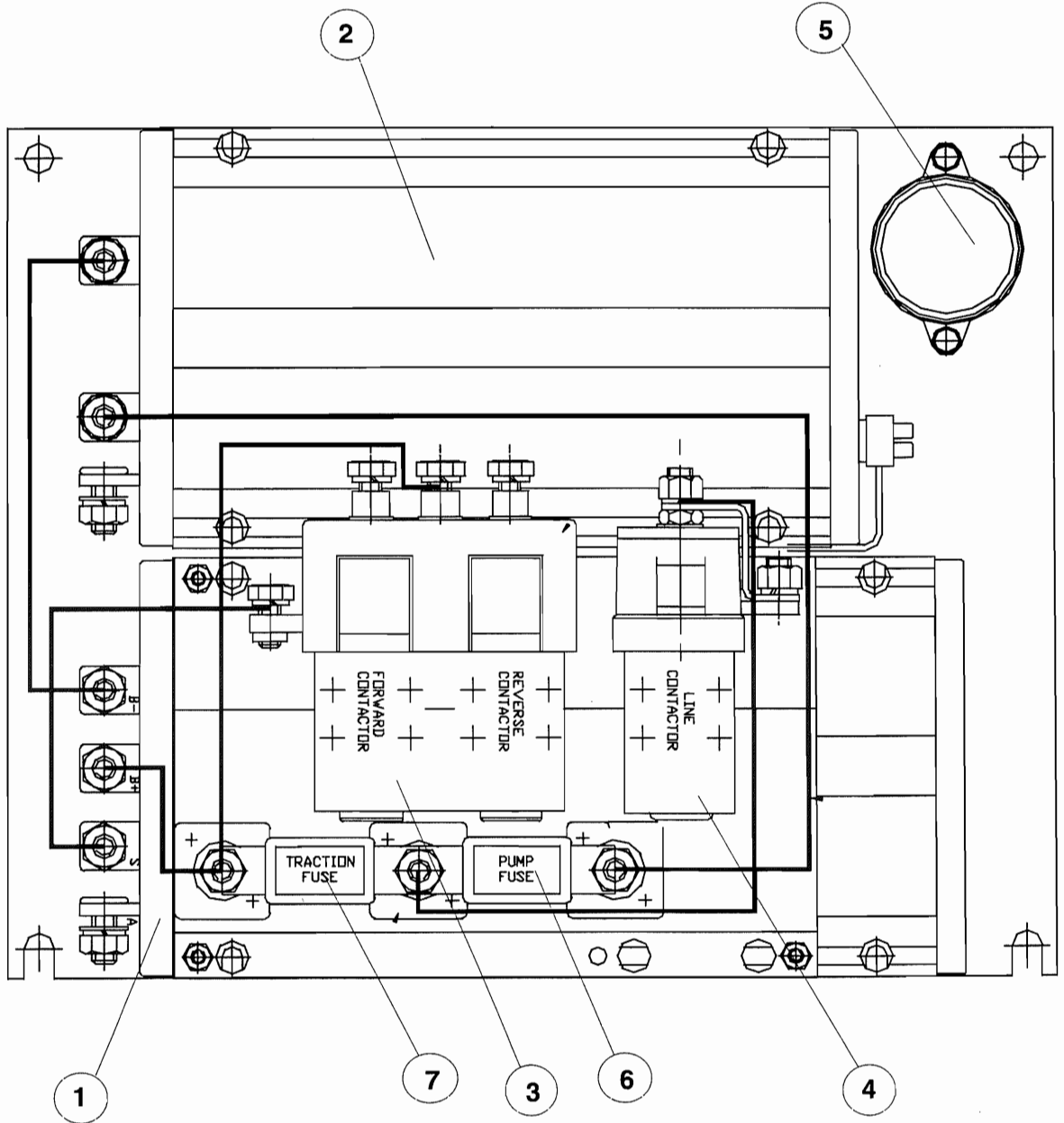

Illustrated Parts Breakdown

LOWER CONTROL BOX (L.C.B.) ASSEMBLY

58121-300 SERIAL NUMBERS 1001 TO 1059

58830-300 SERIAL NUMBERS 1060 TO CURRENT

ITEM	PART-NUMBER	DESCRIPTION	QTY.
1	58133-300	ENCLOSURE	1
2	57591-000	P.C.B. ASSEMBLY - SERIAL NUMBERS 1001 TO 1022	1
	57592-000	P.C.B. ASSEMBLY - SERIAL NUMBERS 1023 TO 1035	1
	57593-000	P.C.B. ASSEMBLY - SERIAL NUMBERS 1036 TO 1075	
	57594-000	P.C.B ASSEMBLY - SERIAL NUMBERS 1076 TO CURRENT	
3	58899-000	CABLE ASSEMBLY (L.C.B. - TILT ALARM)	1
4	58900-000	CABLE ASSEMBLY (L.C.B. -TACHOMETER)	1
5	58901-000	CABLE ASSEMBLY (L.C.B. - SLEW CUT-OUT LIMIT SWITCH)	1
6	58902-000	CABLE ASSEMBLY (L.C.B. - BOOM REST LIMIT SWITCH)	1
7	58903-000	CABLE ASSEMBLY (L.C.B. - MOTOR CONTROLLERS)	1
8	58904-000	CABLE ASSEMBLY (L.C.B. - UPPER CONTROL BOX)	1
9	58905-000	CABLE ASSEMBLY (L.C.B. - VALVE SOLENOIDS)	1
10	57310-000	3-POSITION SELECTOR KEY SWITCH	1
11	57309-300	EMERGENCY STOP BUTTON	1
12	57332-400 *	GLAND (LARGE)	1
		LOCKNUT (LARGE)	
13	57308-300 *	GLAND (SMALL)	5
		LOCKNUT (SMALL)	
14	58906-000	CABLE ASSEMBLY (L.C.B. - 8M CUT-OUT LIMIT SWITCH)	2
15	57312-400	SWITCH GUARD	4
16	57311-400	TOGGLE SWITCH	4

Lower Control Box Assembly

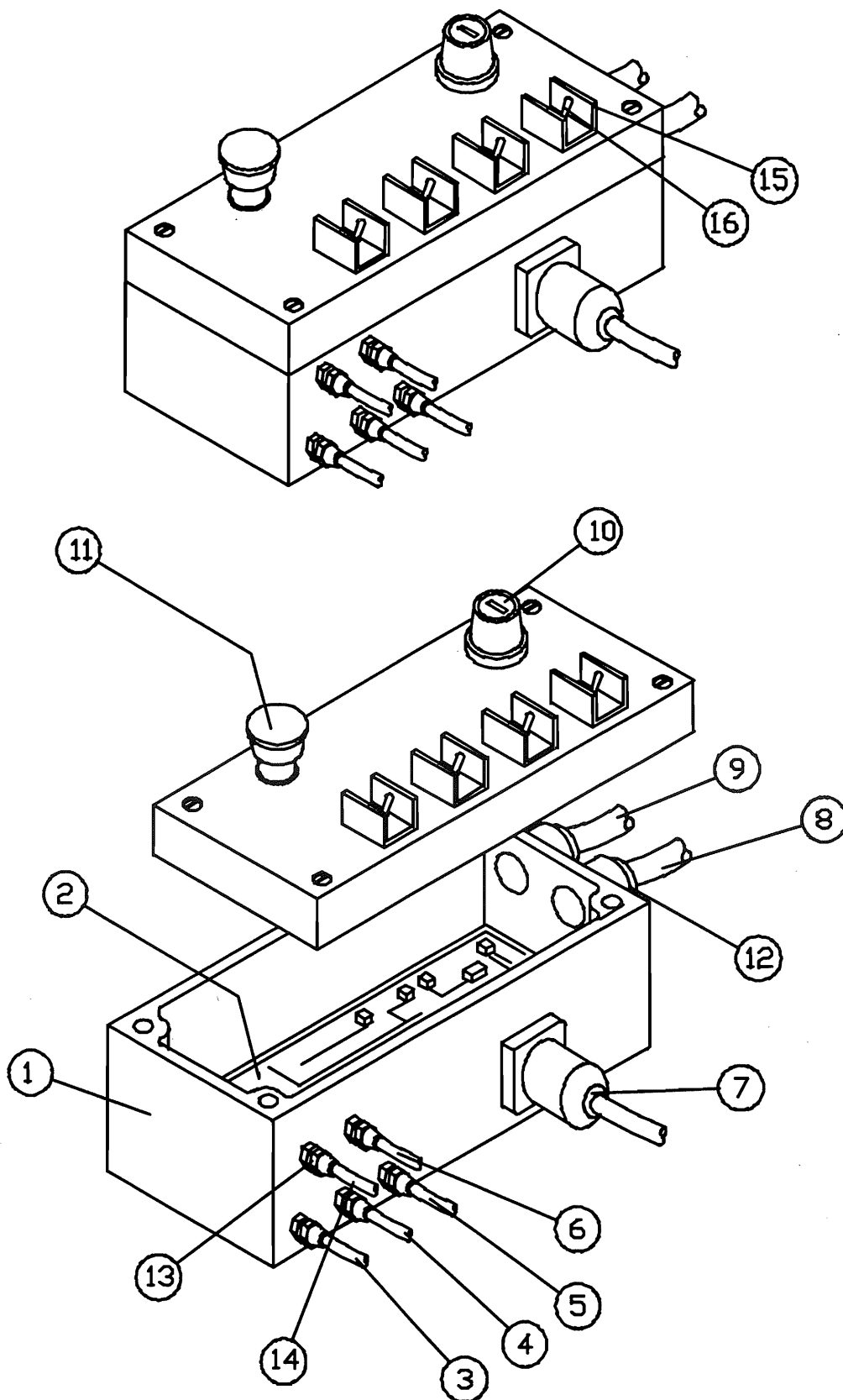

UPPER CONTROL BOX (U.C.B.) ASSEMBLY
57572-300

ITEM	PART-NUMBER	DESCRIPTION	QTY.
1	58150-000	ENCLOSURE	1
2	58804-000	JOYSTICK	1
*	63975-004	POT ASSY	1
*	58984-000	RUBBER BOOT	1
*	58985-000	INTERNAL MICRO SWITCH	1
*	58809-000	STEER ROCKER SWITCH	1
3	58152-000	4-POSITION SELECTOR SWITCH	1
4	57309-000	EMERGENCY STOP BUTTON	1
5	57236-000	P.C.B., UPPER	1
6	57330-000	RED LED	1
7	57329-000	GREEN LED	1
8	57312-400	SWITCH GUARD	1
9	57327-400	ROTARY SWITCH	1
*	58947-000	CONTACT BLOCK N/C	1
*	58946-000	CONTACT BLOCK N/O	1
10	57311-400	TOGGLE SWITCH	1
11	57328-400	BUZZER	1
12	58807-000	2-POSITION DRIVE/LIFT SELECTOR SWITCH	1

Upper Control Box Assembly

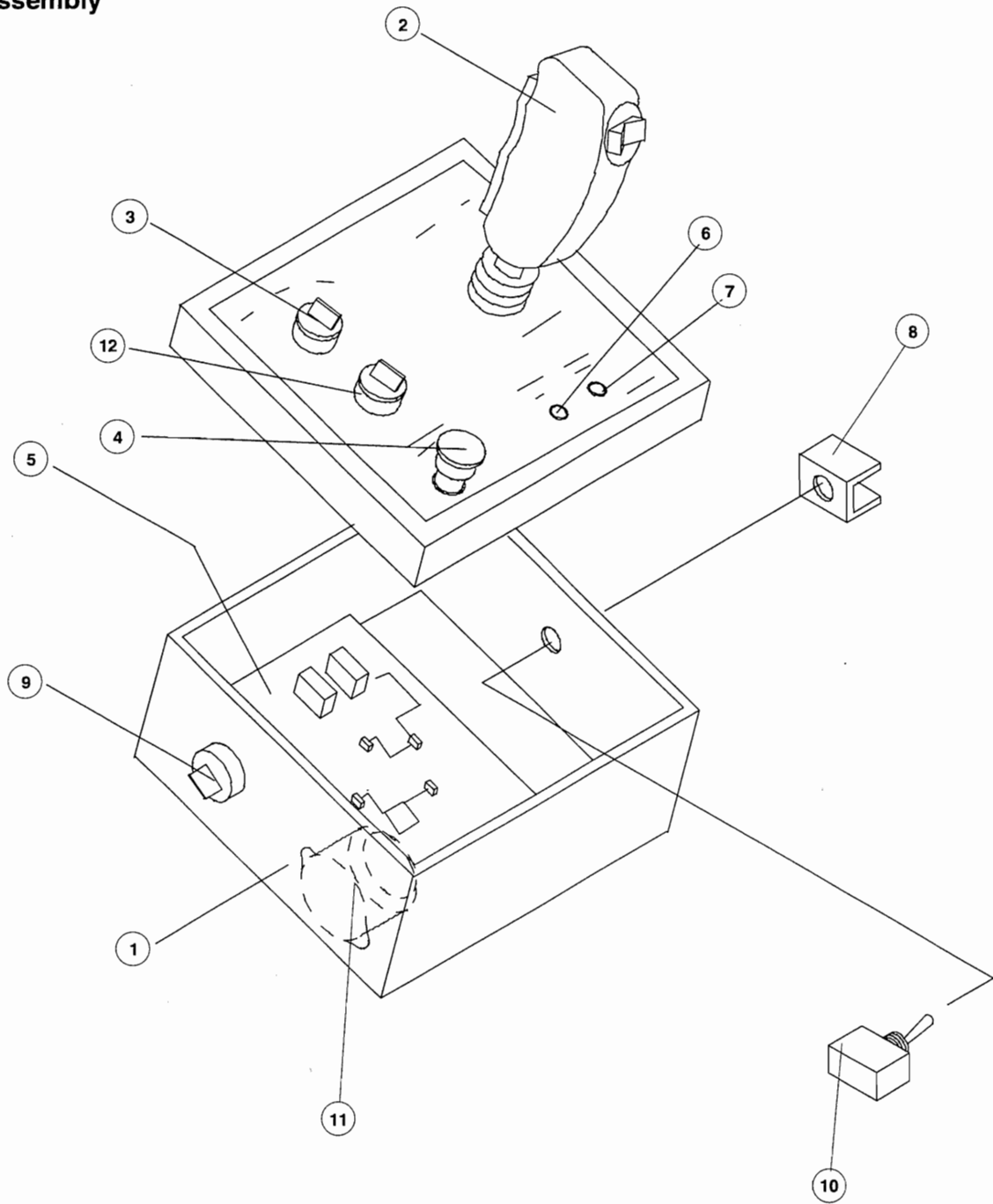

LABEL KIT
57606-200

ITEM	PART-NUMBER	DESCRIPTION	QTY.
1	57385-300	HAZARD TAPE	1
2	57392-300	S.W.L. DECAL	1
3	58990-000	INSTRUCTION MANUAL	1
4	57690-300	'IF WARNING ALARM SOUNDS' DECAL	1
5	58013-300	'BEFORE DRIVING' DECAL	1
6	57692-300	'IMPORTANT, BEFORE USING..' DECAL	1
7	5738-300	'WARNING THIS MACHINE...' DECAL	1
8	57689-300	'OPERATE MACHINE ON..' DECAL	1
9	57695-300	BALLAST STRIPES	1
10	57243-400	EMERGENCY LOWERING PROCEDURE DECAL	2
11	57760-400	HANDPUMP DECAL	1
12	58860-400	DANGER HAZARD TO HANDS	1
13	57396-300	EMERGENCY DOWN - ON/OFF DECAL	1
14	57696-300	UPRIGHT LOGO	2
15	57429-300	BATTERIES FLUID LEVEL	2
16	57430-300	EXPLOSION HAZARD	2
17	57388-300	'WARNING THIS MACHINE IS..' DECAL	2
18	57684-300	NAMEPLATE	1
19	58080-300	CAGE LEVELLING	1
20	57694-300	'UPRIGHT SP37' - ON BOOMS DECAL	2
21	57693-300	'SP37' - ON BALLAST DECAL	1

Illustrated Parts Breakdown

Label Kit

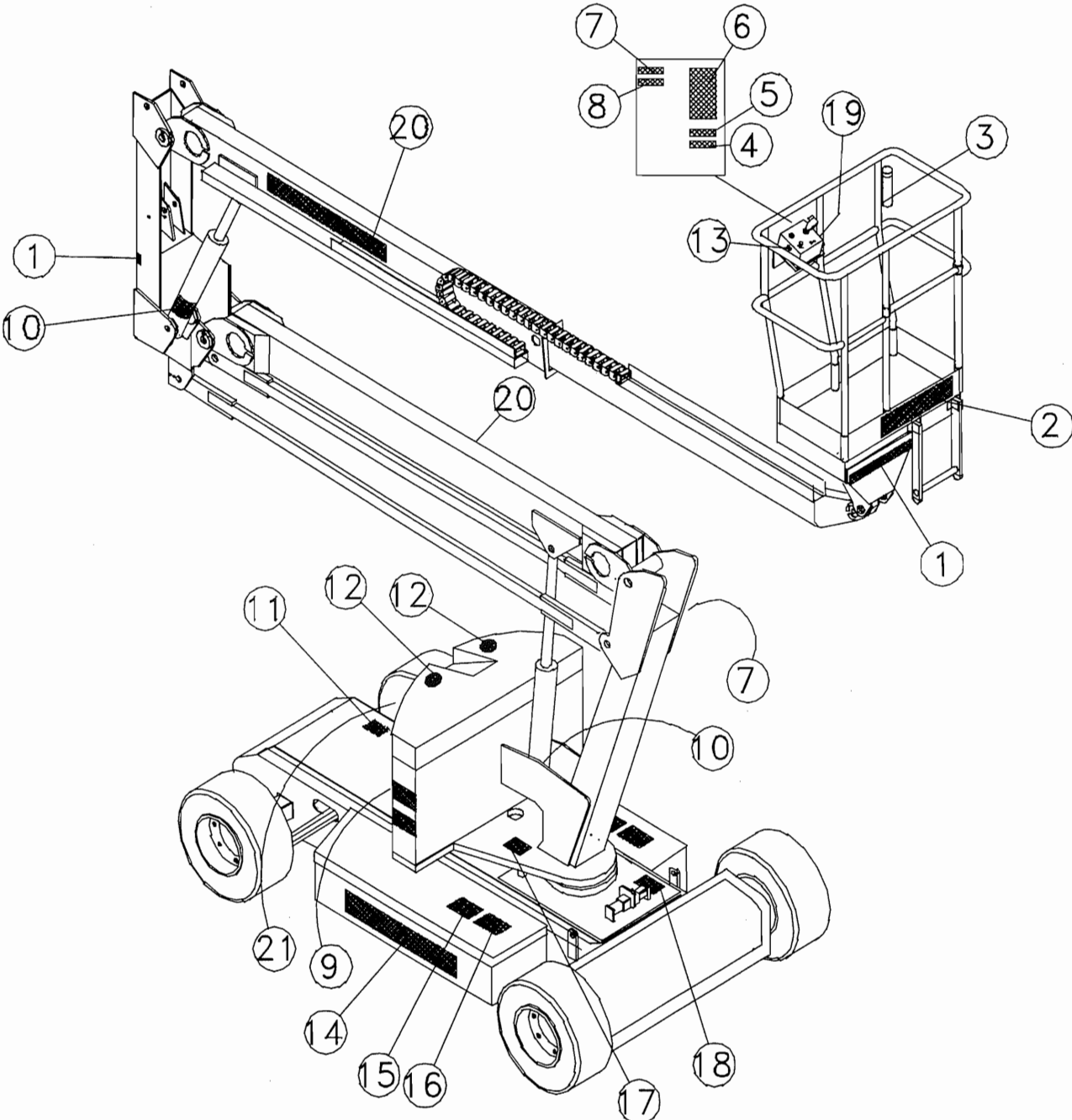

HOSE ASSEMBLY

ITEM	PART-NUMBER	DESCRIPTION	QTY.
1	57550-300	TELE CYLINDER TO MAIN VALVE BLOCK	1
2	57549-300	TELE CYLINDER TO HANDPUMP	1
3	57547-300	LIFT CYLINDER 2 TO MAIN VALVE BLOCK	1
4	57548-300	LIFT CYLINDER 2 TO MAIN VALVE BLOCK	1
5	57545-300	LIFT CYLINDER 1 TO MAIN VALVE BLOCK	1
6	57546-300	LIFT CYLINDER 1 TO MAIN VALVE BLOCK	1
7	57555-300	MASTER CYLINDER TO SLAVE CYLINDER	1
8	57555-300	MASTER CYLINDER TO SLAVE CYLINDER	1
9	57558-300	STEERING CYLINDER TO MAIN VALVE BLOCK	1
10	57559-300	STEERING CYLINDER TO MAIN VALVE BLOCK	1
11	57551-300	SLEW MOTOR TO MAIN VALVE BLOCK	1
12	57552-300	SLEW MOTOR TO MAIN VALVE BLOCK	1
13	57556-300	MAIN VALVE BLOCK TO MASTER CYLINDER	1
14	57557-300	MAIN VALVE BLOCK TO MASTER CYLINDER	1
15	57554-300	MAIN VALVE BLOCK TO BRAKE TEE	1
16	57553-300	BRAKE TEE TO BRAKE	1
17	57561-300	MAIN VALVE BLOCK RETURN TO TANK	1
18	57562-300	SUCTION LINE FROM TANK TO PUMP	1
19	57560-300	PRESSURE LINE FROM PUMP TO MAIN VALVE BLOCK	1
20	57771-300	HANDPUMP SHUT-OFF BALL VALVE TO MAIN VALVE BLOCK	1

Hose Assembly

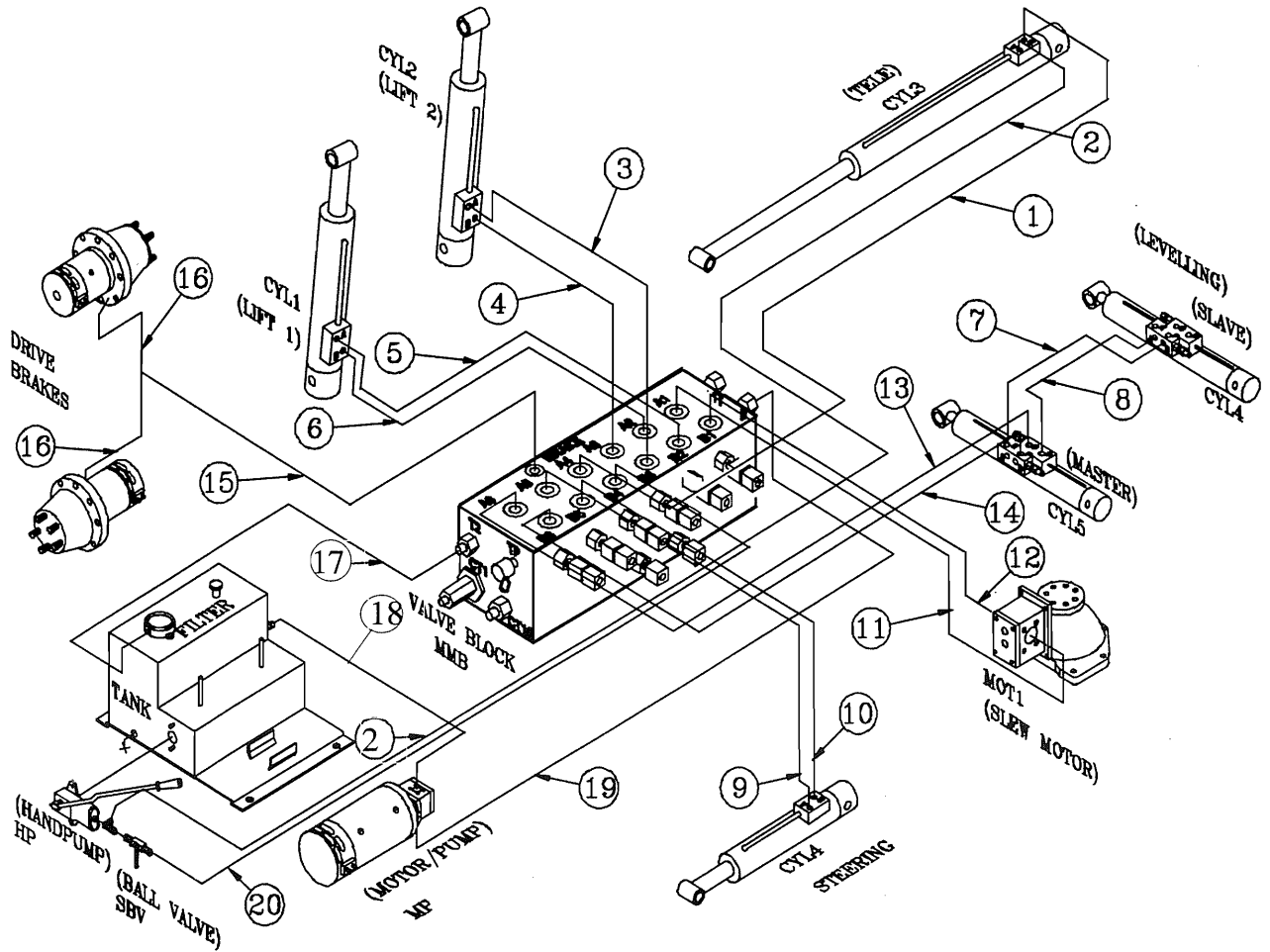

Illustrated Parts Breakdown

MOTOR / PUMP ASSEMBLY 57530-300

ITEM	PART-NUMBER	DESCRIPTION	QTY.
1	58862-000	HYDRAULIC PUMP	1
2	58847-000	COUPLING	1
3	-	OIL SEAL	1
4	-	PUMP MOUNTING FACE	1
5	-	CIRCLIP	1
6	-	BEARING	1
7	-	CIRCLIP	1
8	-	CIRCLIP	1
9	-	COOLING FAN	1
10	-	COMMUTATOR	1
11	-	BEARING	1
12	-	COMMUTATOR COVER	1
13	-	BRUSH HOUSING SUPPORT	1
14	58863-000	BRUSH	4
15	-	END HOUSING	1
16	-	TERMINAL BLOCK	1
17	-	VENT / INSPECTION CAP	4

* MOTOR ASSEMBLY WITHOUT PUMP - 58861-000

Motor / pump Assembly

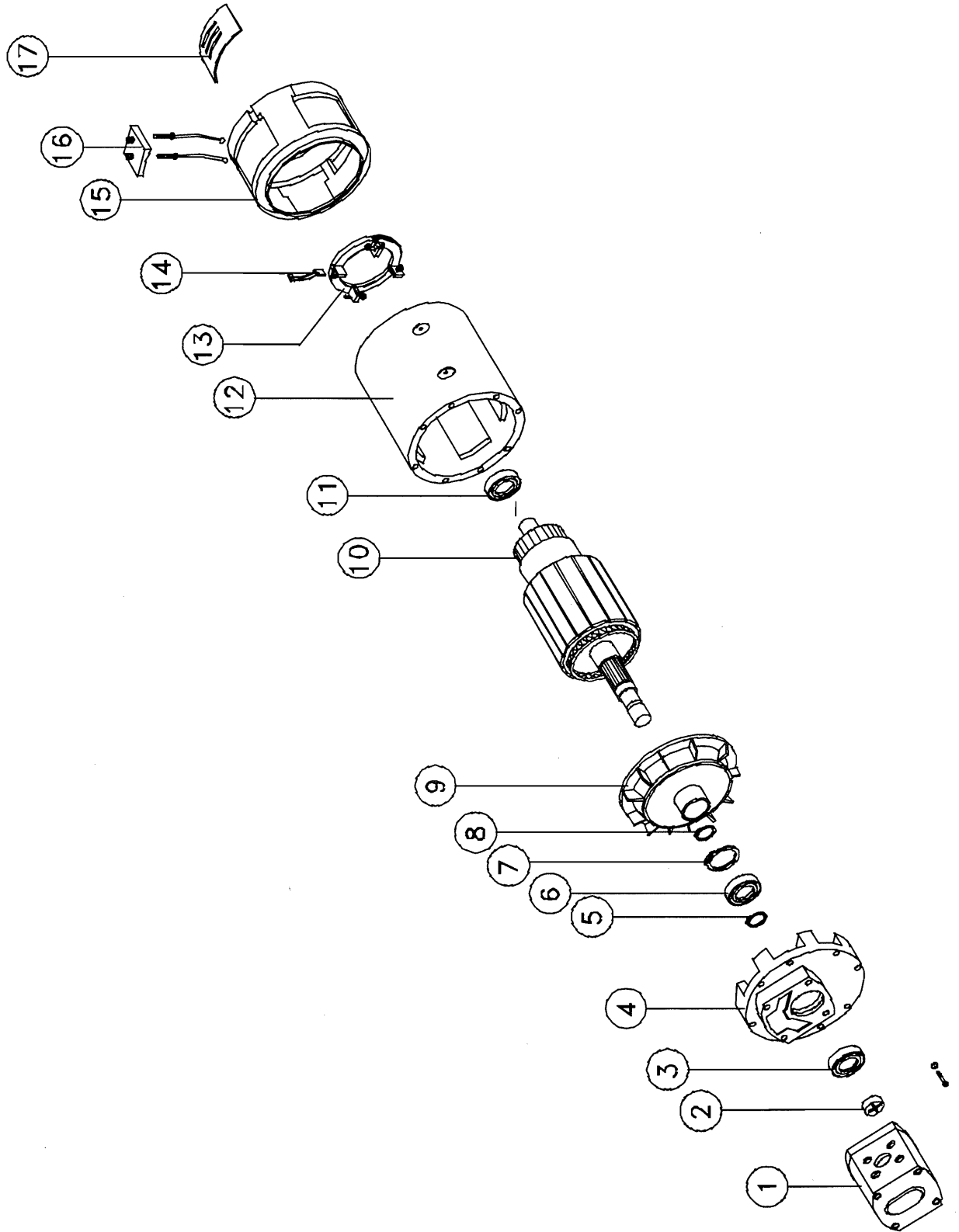

REAR WHEEL ASSEMBLY - 57668-300
FRONT WHEEL ASSEMBLY - 57667-300

ITEM	PART-NUMBER	DESCRIPTION	QTY.
1	57578-000	M14 WHEEL NUT	10
2	58865-300	REAR WHEEL RIM	2
3	58867-300	TYRE (FRONT AND REAR)	4
4	57579-000	M16 WHEEL NUT	10
5	58866-300	FRONT WHEEL RIM	2

Rear (Drive) wheel Assembly

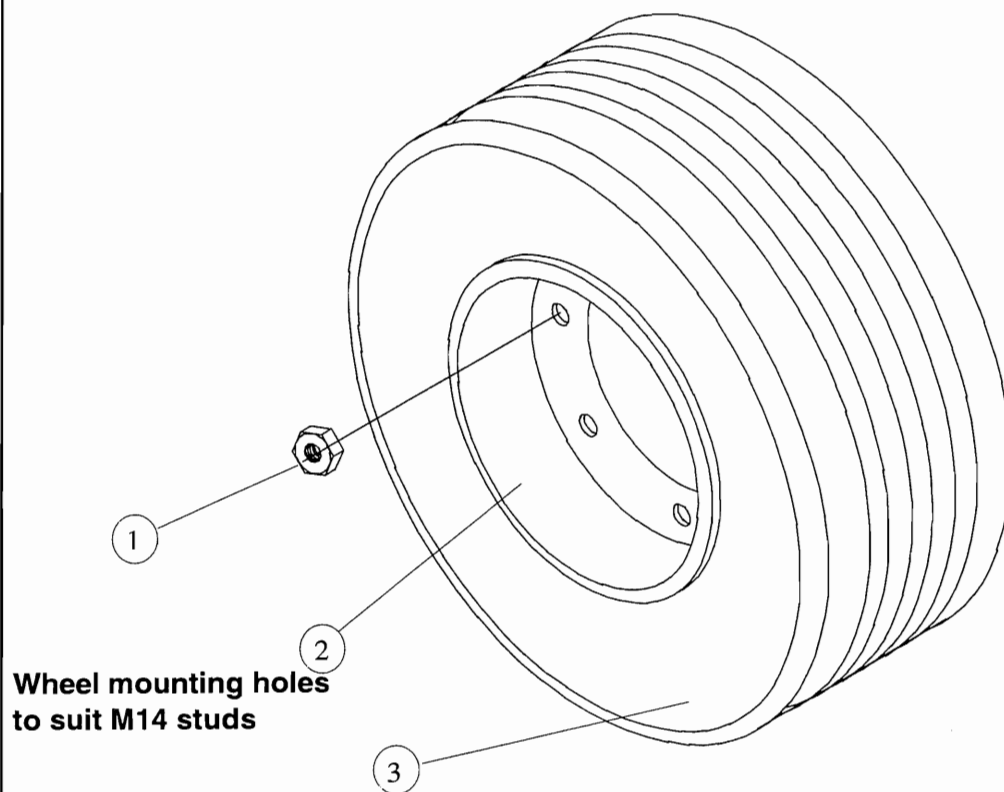

Front (Steer) wheel Assembly

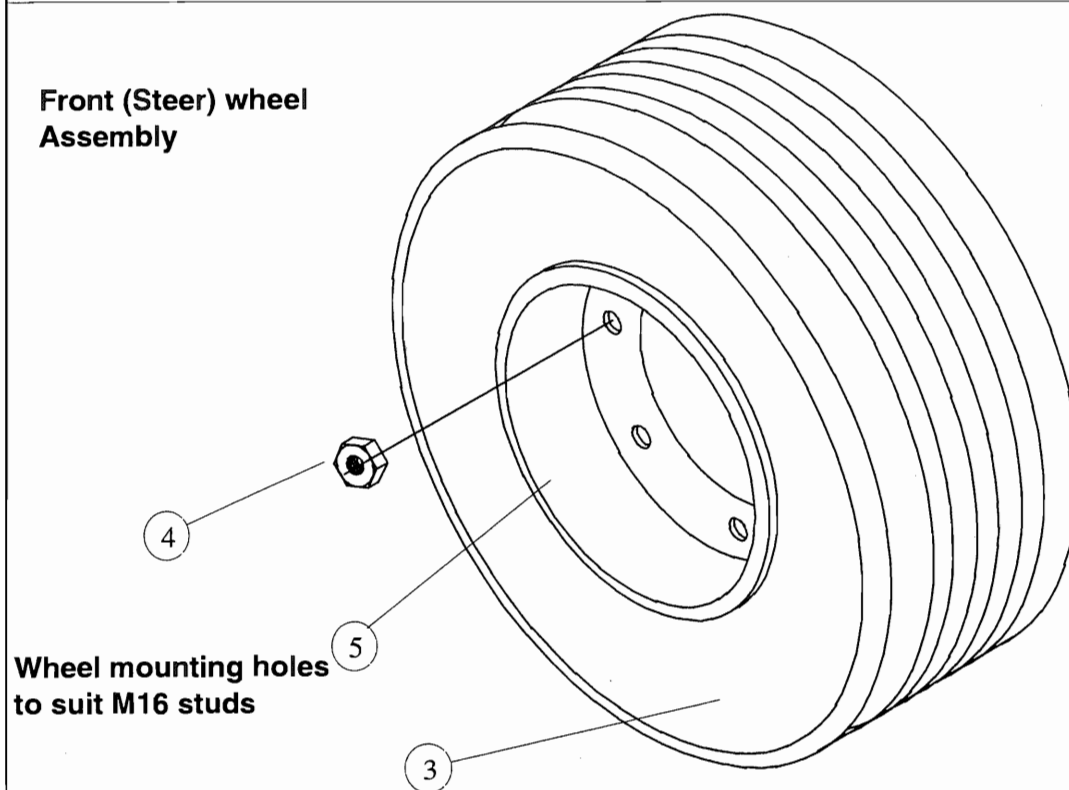

**HYDRAULIC MANIFOLD BLOCK ASSEMBLY
57535-300**

ITEM	PART-NUMBER	DESCRIPTION	QTY.
1	57106-000	PRESSURE TEST POINT FITTING	1
2	57536-000	MAIN RELIEF SET AT 180 BAR	1
3	57537-000	4 WAY 3 POSITION VALVE AND COILS (MOTOR SPOOL)	5
4	57538-000	4 WAY 3 POSITION VALVE AND COILS (CLOSED SPOOL)	1
5	57541-000	POPPET VALVE CARTRIDGE (NORMALLY CLOSED)	1
6	57542-000	POPPET VALVE CARTRIDGE (NORMALLY OPEN)	1
7	57540-000	PRESSURE REDUCER	1
8	57122-000	3/8" MALE - MALE STRAIGHT B.S.P. ADAPTOR	3
9	57125-000	3/8" BONDED SEAL	3
10	57358-000	1/4" MALE - MALE STRAIGHT B.S.P. ADAPTOR	12
11	57124-000	1/4" BONDED SEAL	11
12	57539-000	SLEW CROSS LINE RELIEF VALVE SET AT 50 BAR	2

*** SEAL KIT FOR COMPLETE MANIFOLD BLOCK AND COMPONENTS - 58737-000**

Hydraulic Manifold Block Assembly

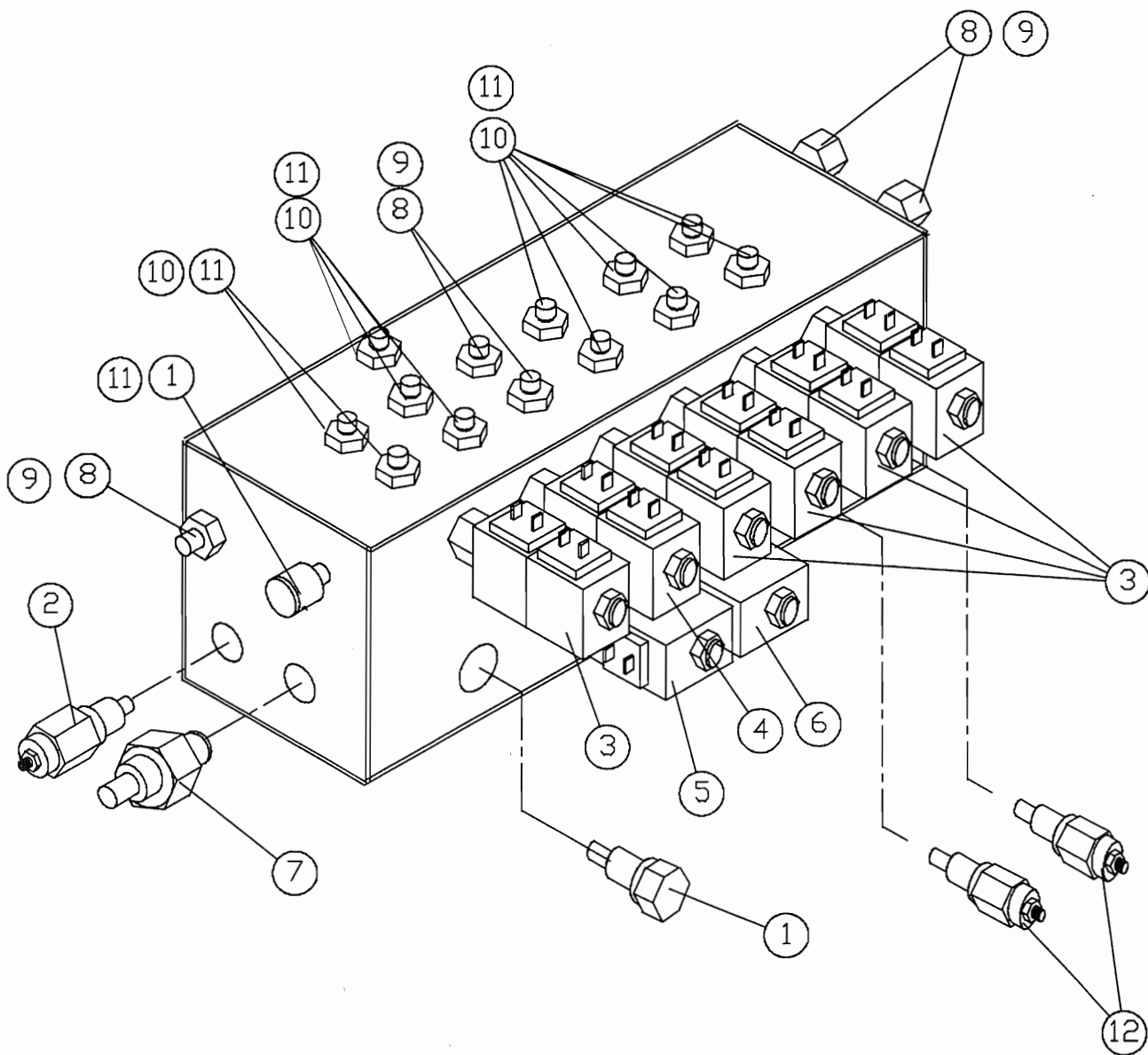

STEERING CYLINDER ASSEMBLY

57682-300

ITEM	PART-NUMBER	DESCRIPTION	QTY.
1	-	STEERING CYLINDER BODY	1
2	-	INLET/OUTLET MANIFOLD	1
3	-	ANNULAR PIPE	1
4	-	END CAP	1
5	-	ROD AND END PIVOT	1
6	SEE NOTE	ROD SEAL	2
7	SEE NOTE	O-RING	1
8	SEE NOTE	WIPER	1
9	SEE NOTE	PISTON O-RING	1
10	58819-000	GREASE NIPPLE	2
11	-	PISTON HEAD	1
12	SEE NOTE	PISTON SEAL	1
13	SEE NOTE	PISTON LOCKNUT	1
14	SEE NOTE	ROLL PIN	1
15	SEE NOTE	GRUB SCREW	1
16	SEE NOTE	END CAP GLAND	1
17	-	TAB WASHER	1

NOTE: ITEMS 6,7,8,9,12,13,14,15 & 16 ALL FORM THE SEAL KIT FOR THE CYLINDER.
THE SEAL KIT IS PART NUMBER 58752-000

Steering Cylinder Assembly

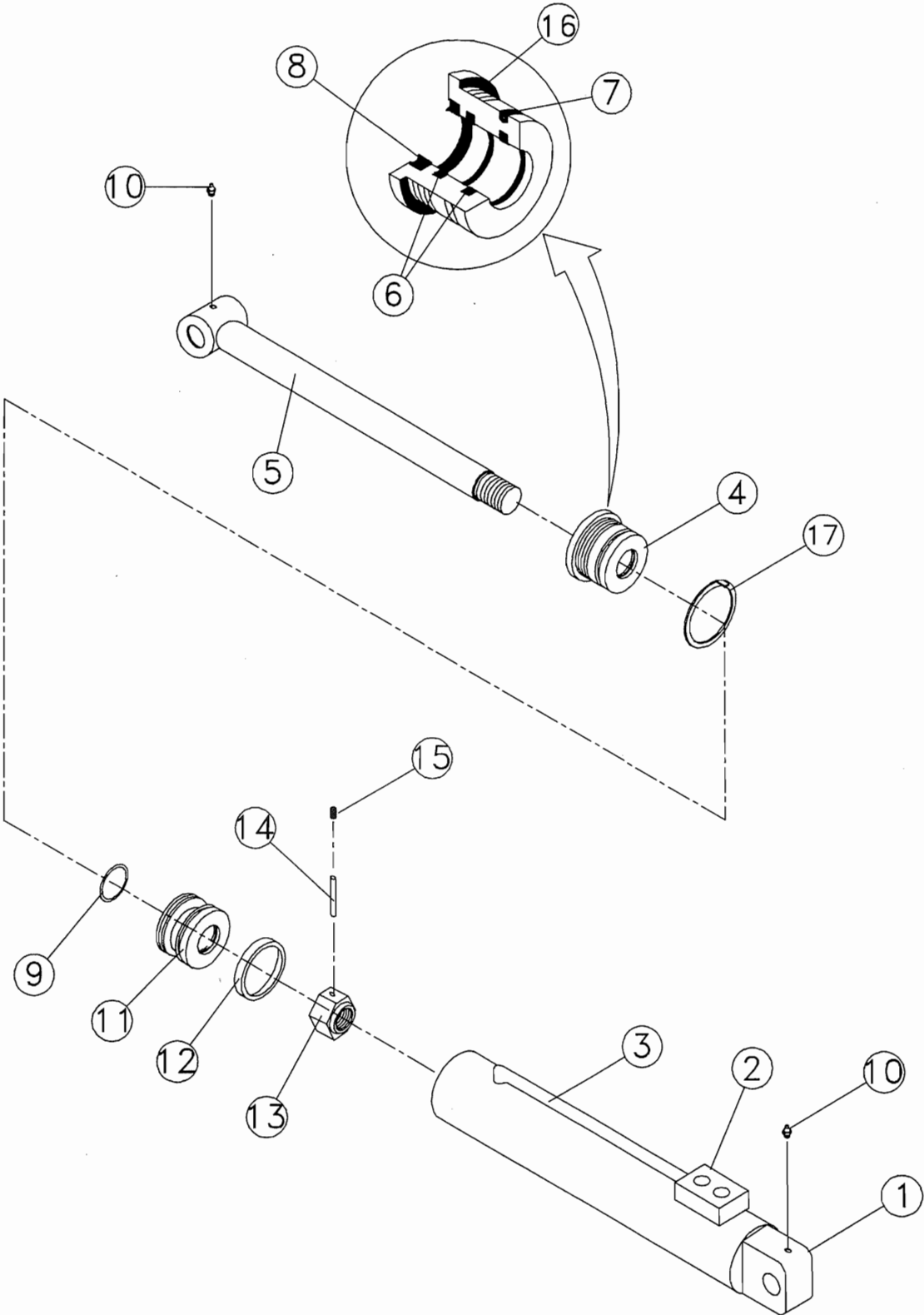

TRACTION MOTOR ASSEMBLY

57568-300 R.H. / 58834-300 L.H.

ITEM	PART-NUMBER	DESCRIPTION	QTY.
1	-	MOTOR MOUNTING FACE	1
2	-	SEAL	1
3	-	CIRCLIP	1
4	-	BEARING	1
5	-	COOLING FAN	1
6	-	COMMUTATOR	1
7	-	BEARING	1
8	-	FIELD WINDINGS	1
9	-	COMMUTATOR COVER	1
10	-	BRUSH BOXES SUPPORT	1
11	-	END FACE	1
12	-	VENT / INSPECTION CAP	4
13	57698-000	BRUSH	4
14	57699-000	BRUSH SPRINGS	4

Traction Motor Assembly

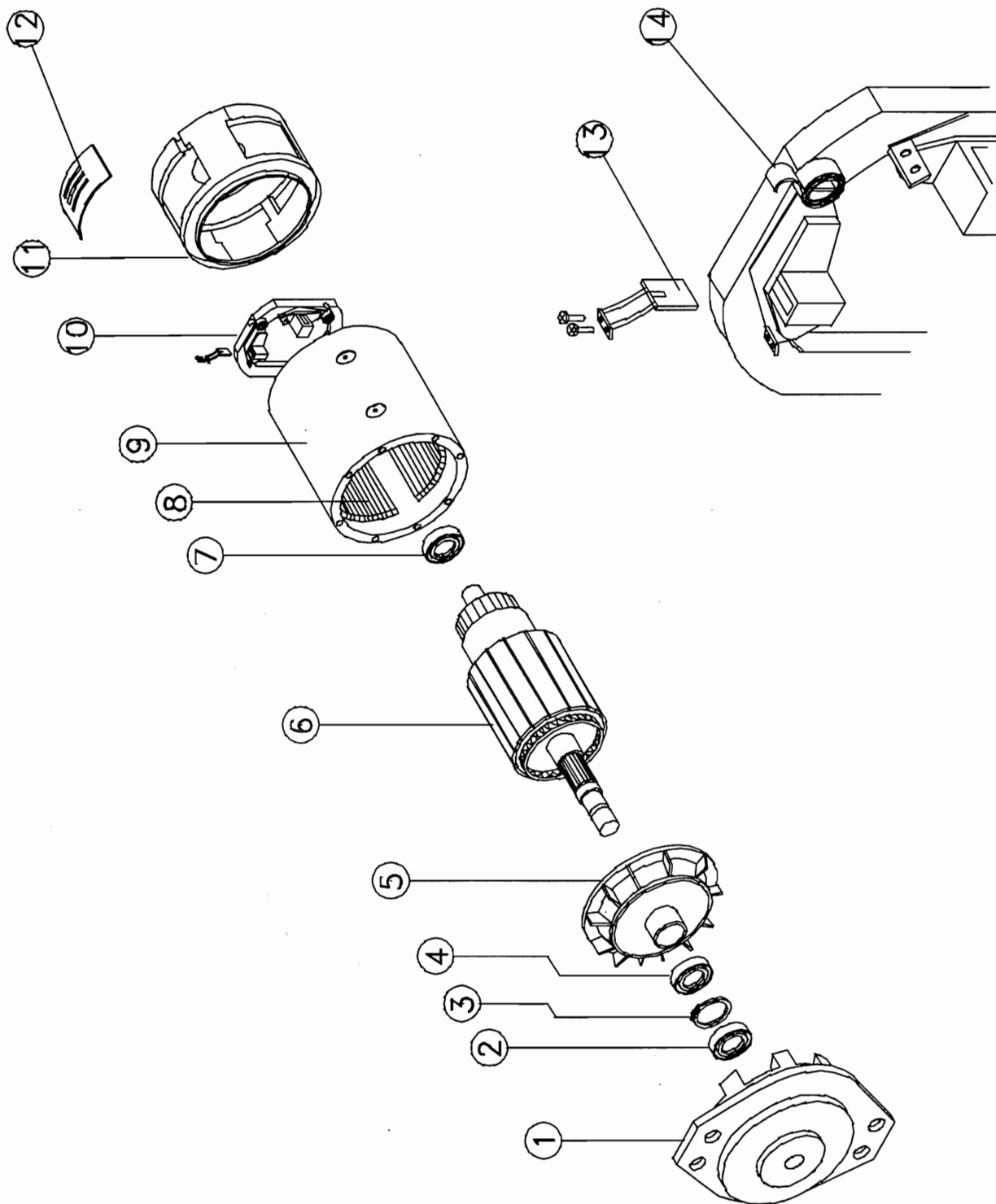

Illustrated Parts Breakdown

DRIVE REDUCTION GEARBOX ASSEMBLY 57580-300

ITEM	PART-NUMBER	DESCRIPTION	QTY.
1	-	COUPLING	1
2	-	EXPANSION PLUG	1
3	-	STEEL DISC	1
4	-	BRONZE DISC	1
5	-	O-RING	1
6	-	SPACER	1
7	-	O-RING	1
8	-	ANTI-EXTRUS. RING	1
9	-	PISTON	1
10	-	SPRING	12
11	-	O-RING	1
12	-	ANTI-EXTRUS. RING	1
13	-	OIL SEAL	1
14	-	END PLATE	1
15	-	O-RING	1
16	-	CIRCLIP	1
17	-	HUB	1
18	-	BEARING	1
19	-	CIRCLIP	1
20	-	PLANET SHAFT	1
21	-	PLANET CARRIER	1
22	-	CIRCLIP	1
23	-	THRUST WASHER	3
24	-	NEEDLE ROLLER	84
25	-	PLANET GEAR	3
26	-	THRUST WASHER	3
27	-	CIRCLIP	3
28	-	SUN PINION	1
29	-	O-RING	1
30	-	BEARING	1
31	-	RETAINING RING	1
32	-	RETAINING RING	1
33	-	INPUT FLANGE	1
34	-	SCREW	8
35	-	SPACER	1
36	-	CIRCLIP	1
37	-	BEARING	1
38	-	COUPLING	1
39	-	BEARING	1
40	-	PIN	1
41	-	SPRING	1
42	-	SUN PINION	1
43	-	CIRCLIP	1
44	-	O-RING	1
45	-	THRUST WASHER	1
46	-	O-RING	1
47	-	RING + BEARING	1
48	-	PLANET SHAFT	3
49	-	SPINDLE	1
50	-	THRUST WASHER	3
51	-	THRUST WASHER	3
52	-	NEEDLE ROLLER	75
53	-	SPACER	3
54	-	PLANET GEAR	3
55	-	NEEDLE ROLLER	75
56	-	THRUST WASHER	3
57	-	THRUST WASHER	3
58	-	WASHER	2
59	-	PLUG	2
60	-	STUD M15 X 1.5	5
61	-	PIN	1
62	-	SCREW	1
63	-	CIRCLIP	1

* Complete seal & O-ring kit - 58799-000

Illustrated Parts Breakdown

CABLES AND ELECTRICAL COMPONENTS

57605-300

ITEM	PART-NUMBER	DESCRIPTION	QTY.
1	58915-300	MOTOR CONTROLLER ASSEMBLY	1
2	57530-300	MOTOR/PUMP ASSEMBLY	1
3	58834-300	DRIVE MOTOR L.H.	1
4	57568-300	DRIVE MOTOR R.H.	1
5	57569-300	TACHOMETER	1
6	15796-001	BATTERY	8
7	57850-000	8m CUT-OUT SWITCH	1
8	57573-300	BATTERY CHARGER	1
9	57281-400	TILT SENSOR	1
10	57850-000	SLEW CUT-OUT LIMIT SWITCH	1
11	57183-000	BOOM REST LIMIT SWITCH (NON ADJUSTABLE LEVER)	1
*	58874-000	BOOM REST LIMIT SWITCH (ADJUSTABLE LEVER, CE MACHINES)	1
12	57587-400	MOTION ALARM	1
13	57586-400	HORN	1
14	58937-000	BATTERY DISCONNECT PLUG	1
15	58902-000	CABLE ASSY - L.C.B. TO BOOM REST LIMIT SWITCH	1
16	58901-000	CABLE ASSY - L.C.B. TO SLEW CUT-OUT LIMIT SWITCH	1
17	58904-000	CABLE ASSY - L.C.B. TO U.C.B.	1
18	58899-000	CABLE ASSY - L.C.B. TO TILT SENSOR	1
19	58906-000	CABLE ASSY - L.C.B. TO 8m CUT-OUT LIMIT SWITCH	1
20	58905-000	CABLE ASSY - L.C.B. TO SOLENOID VALVE COILS	1
21	58900-000	CABLE ASSY - L.C.B. TO TACHOMETER	1
22	58903-000	CABLE ASSY - L.C.B. TO MOTOR CONTROLLER ASSEMBLY	1

Cables and Electrical Components

